

**TREMEC**<sup>®</sup>

Torque Transfer Solutions™

*TR-T-10 Series*  
**10-Speed  
Dual Counter Shaft  
Manual Transmission**

**Service Manual**

SM\_TR-T-10\_0915





---

# Table of Contents

Section 1: General Information.....	4
Safety First.....	4
General Safety Precautions.....	4
Driver Instructions: Shifting the TREMEC 10-Speed Transmission.....	6
Specifications.....	7
Section 2: Maintenance.....	9
Filter Regulator.....	9
Lubrication.....	9
Section 3: General Disassembly.....	10
Note: Important Procedure.....	10
Before You Start.....	11
Section 4: Shift Tower Disassembly.....	12
Section 5: Remote Shift Control Disassembly.....	12
Section 6: External Component Disassembly.....	13
Step-by-Step Procedures.....	13
Section 7: Range Case Disassembly.....	15
Step-by-Step Procedures.....	15
Section 8: Main Case Disassembly.....	19
Step-by-Step Procedures.....	19
Section 9: Countershaft Disassembly and Reassembly.....	22
Countershaft Views.....	22
Pressing Directions.....	23
Section 10: Cleaning and Inspection Procedures.....	23
Section 11: Front Bearing Retainer and Seal Assembly.....	24
Step-by-Step Procedures.....	24
Section 12: Main Case Reassembly.....	25
Step-by-Step Procedures.....	25
Section 13: Range Case Reassembly.....	28
Step-by-Step Procedures.....	28
Section 14: Remote Shift Control Reassembly.....	33
Step-by-Step Procedures.....	33
Section 15: Shift Tower Reassembly.....	34
Step-by-Step Procedures.....	34
Section 16: Troubleshooting.....	35
Noisy Operation.....	35
Noise in Neutral.....	36
Noise In Gear.....	36
Oil Leaks.....	36
Walking or Jumping Out of Gear.....	36
Hard Shifting.....	37
Sticking in Gear.....	37
Dirt.....	37
Fatigue.....	37
Corrosion.....	38
Shaft Fits.....	38
Installation and Removal of Bearings.....	38
Interchangeability.....	38
Clutch Troubleshooting.....	38
Section 17: Component Drawings.....	39
Input Shaft Group.....	39
Main Shaft; Primary Gear Group.....	40
Main Case Gears.....	41
Range Case Gears.....	42
Main Case and Clutch Housing.....	44
Air Control Valve.....	45
Fork and Rail Group.....	46
Range Case.....	47
Main Case - Opti-Lube™.....	48
Air Line Schematic.....	49
Shift Tower.....	50

## Section 1: General Information


---


### Safety First


Carefully read this service manual before beginning any work on your TREMEC transmission.

Throughout this manual, you will see symbols that warn of potential physical danger or product damage if the accompanying instructions are not followed.

Note the following symbols and their meanings.


 **Warning.** This symbol indicates a potentially hazardous situation. If the instructions are not followed, the result could be death or serious injury.


 **Mandatory Action.** This symbol indicates that you must do an activity in order for the transmission to function properly. For example, you must use only one gasket underneath the shift tower. If it is eliminated, or more than one gasket is used, binding can occur. This would prevent proper shifting of the transmission and could damage the unit.


 **Prohibited.** This symbol indicates that you must **NOT** do something in order to avoid damaging the transmission. For example, you must not use sealant underneath the shift tower. Using sealant underneath the tower will prevent proper interlock functioning and could damage the unit.


Be sure you understand all procedures and instructions in this manual before you begin working on your TREMEC transmission. If you have any questions, contact Tremec customer service at 1-800-401-9866.

### General Safety Precautions

 Use a hoist whenever lifting the transmission or shaft assemblies. Using a hoist can help prevent muscle strain or other possible injuries.

 Always wear safety glasses when working on the transmission to help prevent possible eye injury due to small parts (such as snap rings) or metal chips that may fly up unexpectedly during a tear-down or rebuild.

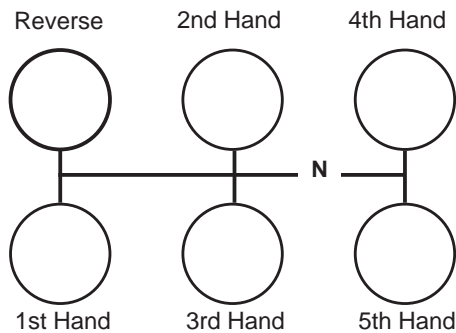
 To avoid injury, be careful when picking up gears or other sharp components. Consider wearing heavy cloth gloves or covering sharp objects with shop towels before picking them up.

 To avoid injury, let the transmission cool down prior to draining the fluid. It is recommended to drain the transmission fluid prior to disassembly of the unit.

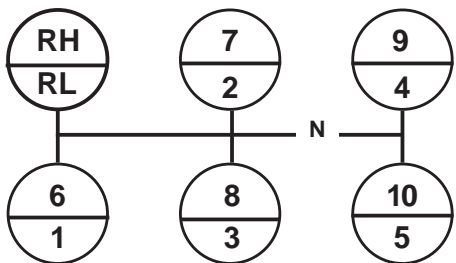
## Section 1: General Information

### Driver Instructions: Shifting the TREMEC 10-Speed Transmission

#### TREMEC 10-Speed Shift Pattern

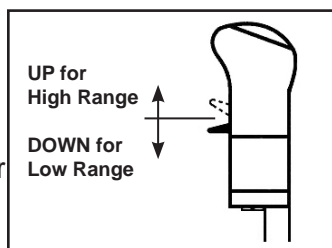


#### Progressive Shift Pattern

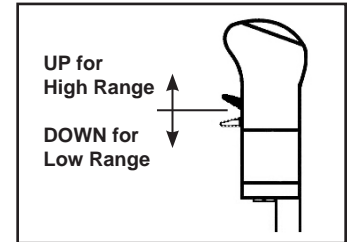


#### Starting Vehicle from a Stop

1.
  - a With the gear shift lever in neutral,
  - b Clutch pedal depressed,
  - c And brakes set.
  - d Start the engine. Allow vehicle to build to maximum air pressure
  
2.
  - a With the clutch pedal fully depressed to engage the clutch brake (see “Clutch Brake”),
  - b Position the range selector to low range. Move the gear shift lever into 1st gear position.
  
3.
  - a Release the tractor parking brakes and trailer parking brakes where applicable.
  - b Release the clutch pedal gradually to full position.
  - c Depress the throttle to start the vehicle moving.
  
4.
  - a After attaining optimal speed in 1st gear,
  - b Depress the clutch pedal.
  - c Move the gear shift lever to neutral (See “Double Clutching: Upshifting”).
  - d Then move the gear shift lever to 2nd gear.



5.
  - a Continue the above procedures through 5th gear position.
  
6.
  - a To continue upshifting (6th gear through 10th gear)
  - b Preselect high range on the range selector.
  - c Depress the clutch pedal.
  - d Move the gear shift lever from the 5th gear position to neutral (See “Double Clutching: Upshifting”)
  - e Then move the gear shift lever into 6th gear position.
  
7.
  - a After attaining optimal speed in 6th gear,
  - b Depress the clutch pedal.
  - c Move the gear shift lever to neutral (see “Double Clutching: Upshifting”)
  - d Then move the gear shift lever into 7th gear position.
  
8.
  - a Continue the above procedure for 3rd hand position (8th gear), 4th hand position (9th gear) and 5th hand positions (10th gear).



#### Trucking Tips

##### Downshifting

Downshifting is actually just the reverse of upshifting (see “Double Clutching: Downshifting”).

##### Clutch Brake

The clutch brake used with this transmission is designed for stopping gear rotation so you can shift into 1st and reverse gears. The last one inch of clutch pedal travel activates the clutch brake. On shifts other than 1st or reverse from a stop, only depress the clutch pedal enough to release the clutch. Depressing the pedal to the floorboard will activate the clutch brake and could cause gear hang-up or hard shifting.

When selecting a starting gear, if you have a butt-tooth condition, gradually release the clutch so the drive gear can rotate to align the gear clutching teeth to complete the shift.

## Section 1: General Information

### Driver Instructions: Shifting the TREMEC 10-Speed Transmission

#### Double Clutching

##### Upshifting:

The normal double clutching technique is suggested. When you want to shift, depress the clutch and move the lever to neutral. Engage the clutch and allow the engine RPM to drop so engine speed and driveline speed match. Depress the clutch and move the gear shift lever into gear. Engage the clutch and accelerate as conditions permit.

##### Downshifting:

Downshifting is the reverse of upshifting. As the engine approaches the shift point (start the downshift approximately 50 -100 RPM above the shift point), depress the clutch and move the gear shift lever to neutral. Engage the clutch and raise the engine RPM until the engine and driveline speeds are equal (normally, governed speed). Depress the clutch, then shift into the next lower gear. Engage the clutch.

##### Skip Shifting:

Experienced drivers sometimes want to skip some of the gear positions. This is acceptable. However, you should do this only when operating conditions allow. Your speed, the load, the road type and condition should be considered.

#### Reminders

- ✓ Double clutch when shifting.
- ✓ Use steady force on the shift lever to complete shifts. Avoid forcing the shift.
- ✓ Don't coast in neutral.
- ✓ Avoid downshifting at road speeds that are too fast.
- ✓ Never change ranges when the transmission is in reverse gear.
- ✓ Chassis and trailer brake life can be increased by downshifting through all the gear speeds when you are slowing down.

#### Reminders



Double clutch when shifting. This will help components match speed better during shifts and will help ensure proper engagement.



Downshift through all gears when you are slowing down. Chassis and trailer brake life can be increased by doing this.



Do not force the shift since this can cause damage to clutch collars and clutching teeth. Use steady force on the shift lever to complete shifts.



Do not coast in neutral. The vehicle could lose RPM's during coasting and you may not be able to shift back into the proper gear.



Do not downshift at road speeds that are too fast. This could prevent proper gear engagement and could damage clutching teeth.



Do not tow vehicles without first pulling the axles or disconnecting the driveshaft. If you tow the vehicle without doing this, you can damage drive train components because the lubrication system is inadequate when the vehicle is towed.

## Section 1: General Information

### Specifications

General	
Direct/Overdrive/Vocational	
Torque Capacity	860 to 1,850 lb.-ft.
Length	28.96 in. (736 mm)
Weight	523 lbs (237 kg)
Input Shaft	2-inch 10-Spline
Output Shaft	2.5-inch 10-Spline
Clutch Housing	Aluminum SAE #1 or #2
Lube Capacity	18 pints (8.5 liters)
Lube Type	CD50 Synthetic

Gear Ratios												
Model No.	Overall Ratio	R1	1	2	3	4	5	6	7	8	9	10
TR-T-10D (Direct Drive)	14.95	16.71	14.95	11.01	7.96	5.98	4.50	3.32	2.45	1.77	1.33	1.00
% Step				36	38	33	33	36	36	38	33	33
TR-TO-10S (Overdrive)	16.72	14.02	12.54	9.24	6.68	4.80	3.60	2.61	1.92	1.39	1.00	0.75
% Step				36	38	39	33	38	36	38	39	33
TR-T-10V (Vocational Direct Drive)	19.02	21.27	19.02	14.02	10.13	7.28	5.20	3.66	2.70	1.95	1.40	1.00
% Step				36	38	39	40	42	36	38	39	40
TR-TO-10V (Vocational Overdrive)	18.88	15.19	13.59	10.01	7.24	5.20	3.71	2.61	1.92	1.39	1.00	0.72
% Step				36	38	39	40	42	36	38	39	41

Power Take-Off Applications		
	Direct Drive	Overdrive
PTO Gear Data	66.7% Engine Speed 45 Tooth, 6 Pitch	85% Engine Speed 45 Tooth, 6 Pitch
Positions	6 Bolt Right, 8 Bolt Left	6 Bolt Right, 8 Bolt Left

End Fitting Reference	
End Yoke	Part Number
1710	6-4-6611-1
1760 & 1760HD	6.3-4-651-1
1810	6.5-4-3451-1
SPL 250	250-4-561-1
RPL 25	25WYS40-2

## Section 1: General Information

### Specifications

Torque Specification for Nuts and Cap Screws						
Part Name	Nominal Thread Size		Wrench Toque (lb-ft)			
			Non-Locking Type		Locking Type (Bonded nylon patch)	
Cap Screw or Nut	Inch	mm	Min.	Max	Min.	Max.
	.250	6	7	10	10	13
	.312		13	17	20	24
	.375	10	25	32	34	41
	.438		40	50	52	62
		12			60	80
	.500		60	80	78	98
		14			80	100
	.562		90	115	112	137
	.625		120	150	150	180
	.750		200	250	240	290
Nut	1.250				400	450
	1.375				550	600
	1.750				550	600
PTO Aperture Cover Cap Screw	.375		10	15	16	24
PTO Aperture Cover Cap Screw with Gasket 97-324-2	.438		20	25	36	41
PTO Aperture Cover Cap Screw with Gasket 22P22	.438		20	25	29	34




## Section 2: Maintenance

### Filter Regulator


Figure 2.1

The 10-speed uses an air filter regulator preset at 55-61 psi.

 Do not disassemble the air filter regulator; it is not field-repairable. If the filter regulator is not operating properly or is damaged, replace it.



### Lubrication

 **CAUTION:** To ensure proper lubrication and operating temperatures in this unit, the proper lubricants must be used.

Correct oil levels must be maintained. TREMEC recommends using only lubricants produced by reputable, well-known suppliers. If you want to use a lubricant not specified below, please contact your local truck dealer to determine whether the lubricant is suitable for your purposes.

#### Recommended Lubricants


The lubricants listed below are recommended for use in TREMEC commercial vehicle mechanical transmissions, and auxiliary transmissions.

Lubricant Specifications		
For TREMEC mechanical transmissions and auxiliaries used in commercial vehicles, the following lubricants are recommended.		
Description	Grade	Type
All Temperature	CD 50	Synthetic engine oil meeting MIL-L-2104 D or MIL-L-46152B, API-SF or API-CD
Oil Cooler		See OEM application requirements

### Oil Changes

Many factors influence oil change periods.

Changes should be scheduled at three years or 250,000 miles with synthetic engine oil for normal over-the-highway operations. Off-highway use usually requires an oil change every 1,000 hours.

 The oil level in the transmission should be checked every 5,000 miles (8,045 km) on-highway, or every 40 hours in off-highway operation. When it is necessary to add oil, TREMEC does not recommend mixing oil types or oil brands. The correct oil level in this transmission is established by the fill plug opening.

### Refill

First, remove all dirt around the fill plug. Then refill the transmission with the recommended lubricant. The lubricant should be level with the oil fill plug located on the left side of the transmission case.

### Overfilling

 **CAUTION:** Do not overfill the transmission.

This usually results in oil breakdown due to excessive heat and aeration from the churning action of the gears. Early breakdown of the oil will result in heavy varnish and sludge deposits that plug up oil ports and build up on splines and bearings.

## Section 3: General Disassembly

---

### Note: Important Procedure

To locate and correct transmission and/or auxiliary transmission issues, a systematic procedure should be followed.

Road test whenever possible. Technicians usually get second or third-hand reports of trouble experienced with the transmission. These reports do not always accurately describe the actual conditions.

Symptoms may indicate trouble in the transmission, while actually the problem is with the axle, driveshaft, universal joints, engine or clutch. This is especially true of noise complaints. Before removing the transmission to diagnose an issue, road test to check the possibility of trouble in other closely associated components.

Road testing is most effective when the technician drives the vehicle. However, riding with the driver can be very informative.

#### Check Functioning Prior to Disassembly

If a remote shift control is used, a careful check of the remote and connecting linkages (and their adjustment) must be made. The remote unit must be in good working order if the transmission is expected to shift properly.

#### Inspect Thoroughly During Disassembly

As the transmission is disassembled, inspect each part to ensure that it is not worn, damaged or no longer meets factory specifications. After the transmission is completely disassembled, check the lubricant for foreign particles. This is a source of trouble often overlooked during the disassembly.

#### Repair or Replace Worn Parts

All parts and components should be carefully examined. All parts that are damaged, worn or no longer meet specifications should be replaced.

Parts that are worn to the extent that they do not have a long service life remaining should be replaced. Replacing these parts now will avoid another teardown in the near future.

Making the recommended changes or modifications will bring the transmission up to date and increase the service life of the unit.

## Section 3: General Disassembly

---

### Before You Start



Read this section before starting the detailed disassembly procedures. Follow procedures closely.

#### Rebuild Facilities

A suitable holding fixture or overhaul stand with a hole for the input shaft is desirable.

For easier working conditions, table height should be 28 - 30 inches. A light chain hoist should be used to handle the mainshaft and countershafts during removal and reassembly procedures.

#### Cleanliness

Transmissions should be steam cleaned prior to disassembly. Seal all openings before steam cleaning to prevent entry of dirt and water which can damage serviceable parts.

Dirt is abrasive and will cause premature wear of bearings and other parts. TREMEC suggests that technicians have a wash tank available to clean parts just prior to reassembly.

#### Bearings

When a transmission is removed at relatively low mileage, bearings should be removed with pullers designed for this purpose. Wrap the bearings to keep out dirt. Clean, inspect, and lubricate all bearings just prior to reassembly. If accumulated mileage is over 150,000 miles, we suggest that all bearings be replaced. If bearings are worn or damaged, always replace them regardless of mileage.



Do not hammer on end yokes and flanges to remove or install them. It is not only destructive to the yoke or the flange itself, but can also cause serious internal transmission damage.

Hammering destroys or mutilates the pilot diameters and warps or bends the flange. Hammering on end yokes will close-in the bearing bores or misalign yoke lugs. This will result in early failures of journal needle bearings.

Serious damage can be done internally to bearings, thrust faces and washers by hammering on external parts. In most designs, when the

yoke/flange locknuts are tightened and secure, the internal bearings and gears are in proper location. When the yoke/flange is driven on the shaft, however, two conditions can exist.

- (1) If the bearing fit is tight on the shaft, usually the bearings will brinell as they must absorb the pounding force.
- (2) If the bearing fit is loose, the shaft will keep moving inward until it is stopped by the internal parts such as the pilot bearing thrust washers.

These conditions must be prevented.

#### Power Take-Offs

Refer to your owner's manual, installation procedures, and safety precaution when installing any PTO on your transmission.

## Section 4: Shift Tower Disassembly

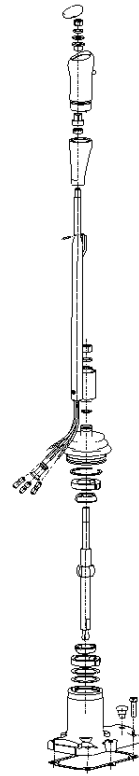
### Shift Tower

Figure 4.1

Steps:

1. Remove shift bezel, nut, lock washer and washer.
2. Disconnect air lines from shift knob.
3. Remove shift knob.
4. To separate upper lever from the lower lever, remove nut and washer on top of the isolator. Pull levers apart.

See Figure 17.12 for Shift Tower component identification



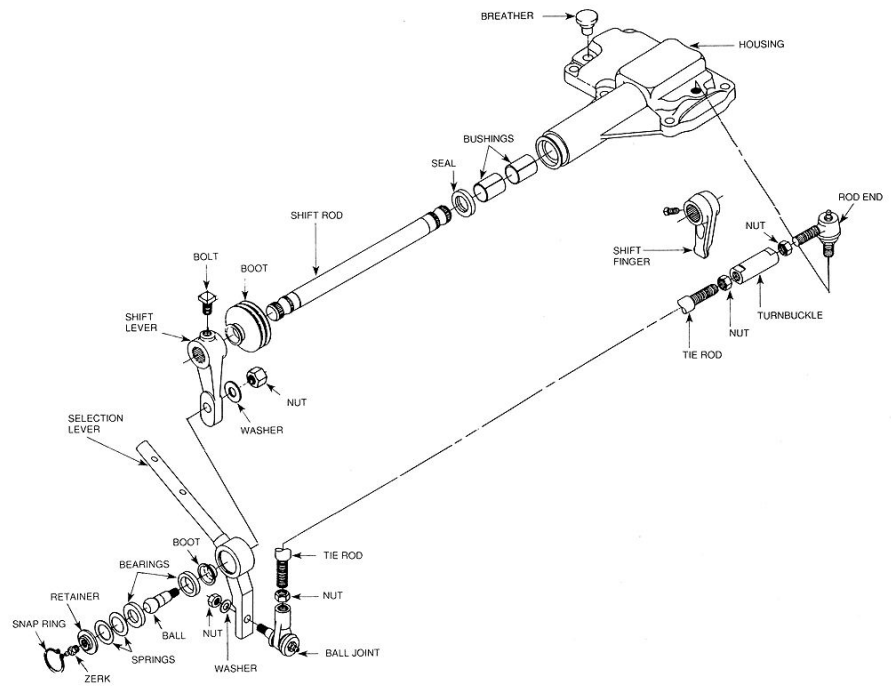
## Section 5: Remote Shift Control Disassembly

### Remote Shift Control

Figure 5.1

Steps:

1. Remove the six retaining bolts; separate the remote shift control from the transmission.
2. Disconnect the tie rod from the housing and the selection lever.
3. Disconnect the selection lever from the outer shift lever.
4. Remove the bolts from the outer shift lever. Tap the lever off the shift rod.
5. Cut the tie straps from the boot and remove it.
6. Remove the shift finger bolts and tap the finger off the rod.
7. Pull the rod from the housing.
8. To disassemble the selection lever subassembly, remove components in this order:
  - A. Snap ring and retainer plate.
  - B. Bearing race, ball stud and retainer plate.
  - C. Two springs and the boot.



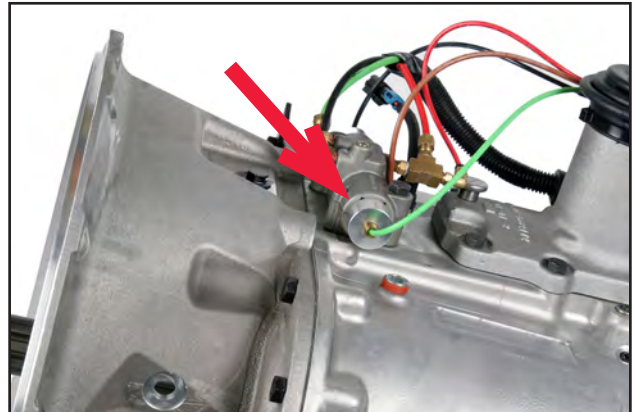
## Section 6: External Component Disassembly

### Step-by-Step Procedures

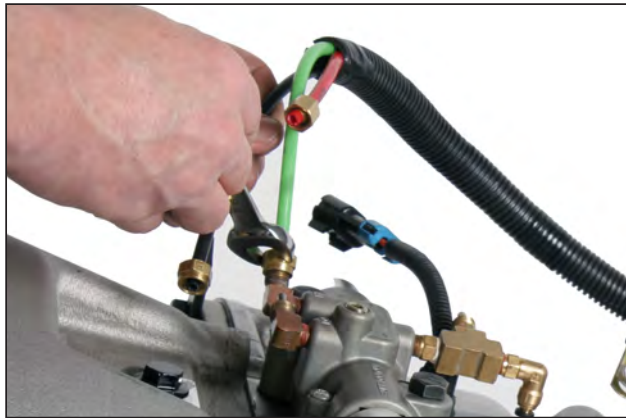
Figure 6.1



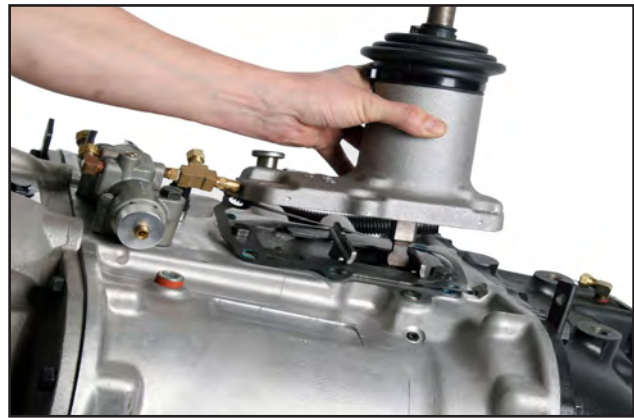
**Step 1:** Start tear down by setting transmission on a sturdy bench.



**Step 2:** Remove air line from the fitting by pushing the bushing inwards with a small screwdriver and then pull out the tubing. Never use side cuts to remove an air line.



**Step 3:** Remove all remaining air lines.



**Step 4:** Remove the 6 shift tower bolts, the shift tower and shift tower gasket.



**Step 5:** Remove the 2 bolts securing the interlock plate to the transmission. Remove the interlock plate and the interlock.



**Step 6:** Remove the 3 springs.

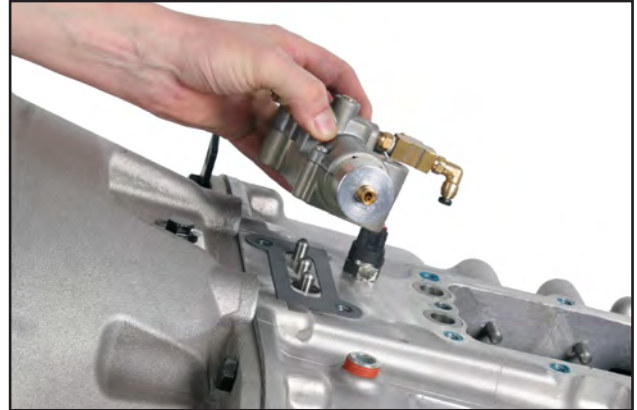
## Section 6: External Component Disassembly

### Step-by-Step Procedures

Figure 6.1



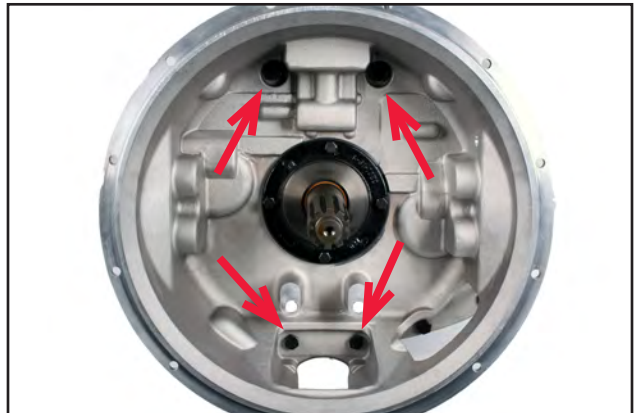
**Step 7:** Remove the 3 poppet balls located under the springs.



**Step 8:** Remove 2 bolts securing the range control valve to the transmission. Remove range control valve and 3 interlock pins.



**Step 9:** Remove range control valve gasket. Remove the backup light switch and pin



**Step 10:** Remove 4 clutch housing bolts from hydraulic clutch housing. (Note: Mechanical clutch housing only has 2 bolts in the upper position on the clutch housing.) Remove all but 4 bolts securing the clutch housing to the main case.

## Section 7: Range Case Disassembly

### Step-by-Step Procedures

Figure 7.1



**Step 1:** Lift the transmission with a hoist and stand on end on a workbench that contains a hole for the input shaft.



**Step 2:** Remove the end yoke or flange.



**Step 3:** Remove the 4 range case piston housing bolts and the range case piston housing.



**Step 4:** Remove the nut securing the range piston to the range fork.



**Step 5:** Remove the piston and the O-ring under the piston.



**Step 6:** Remove the 8 countershaft bearing retainer cap bolts (4 per retainer). Remove the retainer caps and the air filter regular.

## Section 7: Range Case Disassembly

### Step-by-Step Procedures

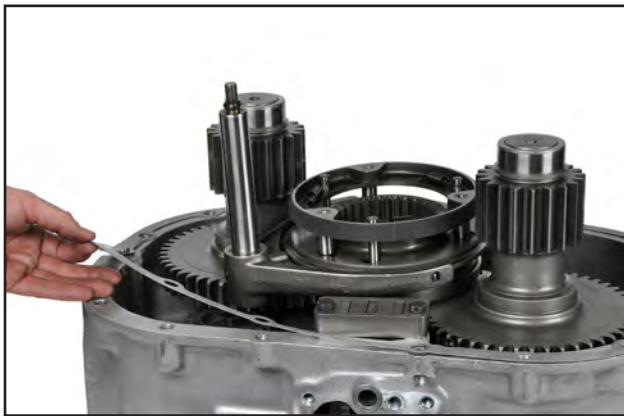
Figure 7.1



**Step 7:** Remove the 4 bolts securing the rear bearing retainer to the transmission. Then remove the rear bearing retainer, shims and speedo gear.



**Step 8:** Remove the 16 range case bolts. Use a chain hoist to lift the range case from the unit. Using pry bars in the milled slots will make the removal easier.



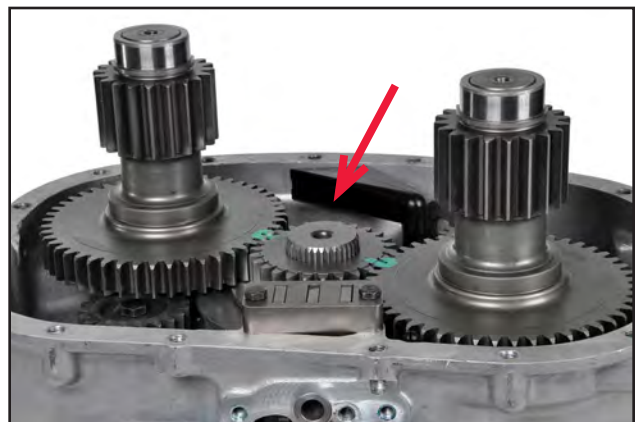
**Step 9:** The output shaft and low range gear will remain in the range case. Remove the range synchronizer and range fork assembly. Remove gasket.



**Step 10:** Be aware that separating the synchronizer will suddenly release the springs.



**Step 11:** Remove the high range synchronizer cup and high range clutch gear by removing the retaining bolt and washer.



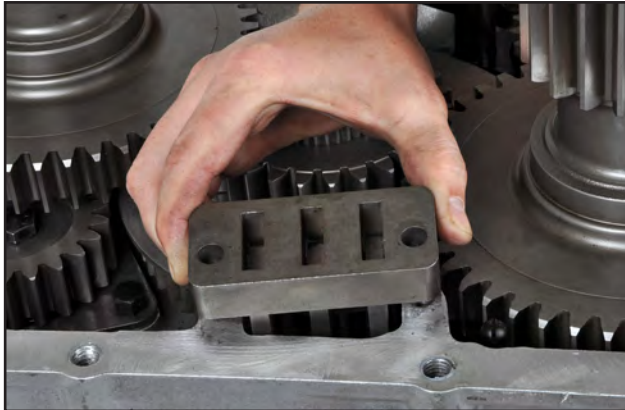
**Step 12:** Lift and remove the high range gear from the case (notice timing marks on gear).



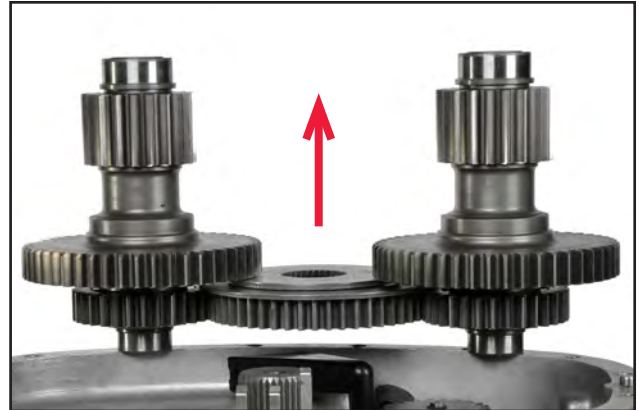
## Section 7: Range Case Disassembly

### Step-by-Step Procedures

Figure 7.1



**Step 13:** Remove the 2 bolts securing the shift bar support bracket to the transmission. Lift and remove the shift bar support bracket.



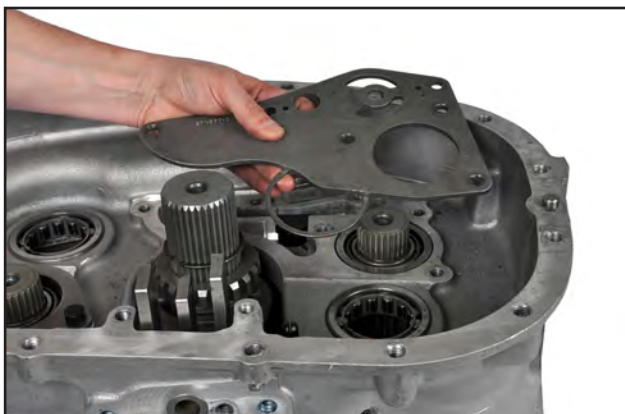
**Step 14:** Simultaneously lift both countershafts straight up to remove them. The mainshaft reverse gear and rear thrust plate should come out at the same time.



**Step 15:** Remove the 2 bolts securing the countershaft reverse gears and washers. Remove both countershaft reverse gears and washers.



**Step 16:** Remove the 2 retaining bolts for the Opti-Lube™ pump housing. Remove the Opti-Lube pump assembly.



**Step 17:** Remove the 4 bolts for the left countershaft bearing retaining plate. Lift and remove the retaining plate and shims.



**Step 18:** Remove the oil bypass valve.

## Section 7: Range Case Disassembly

### Step-by-Step Procedures Figure 7.1



**Step 19:** Remove the right 3 countershaft retaining plate bolts. Remove the retaining plate and shims.



**Step 20:** Remove the output shaft from the case.



**Step 21:** The output bearings and spacers are a matched set. If necessary to replace any of the components, replace the whole set to ensure proper end play.

## Section 8: Main Case Disassembly

### Step-by-Step Procedures

Figure 8.1



**Step 1:** Remove the four remaining case bolts. Use hoist to help separate the case from the clutch housing. The use of pry bars in the milled slots will make the removal of the case much easier.



**Step 2:** Remove the mainshaft snap ring.



**Step 3:** Remove the 1st and Reverse clutch collar and fork.



**Step 4:** Spread the countershafts apart.



**Step 5:** Remove the 1st and 2nd speed gears.



**Step 6:** Remove 2nd and 3rd speed clutch collar and fork.

## Section 8: Main Case Disassembly

### Step-by-Step Procedures

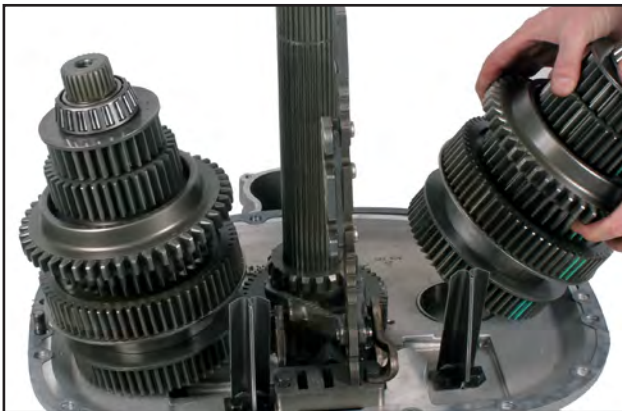
Figure 8.1



**Step 7:** Remove the 3rd speed gear



**Step 8:** Remove the 4th speed gear (5th gear if working on an overdrive transmission).



**Step 9:** Remove the countershafts.



**Step 10:** Remove the gasket.



**Step 11:** Remove the mainshaft and 4th-5th collar.

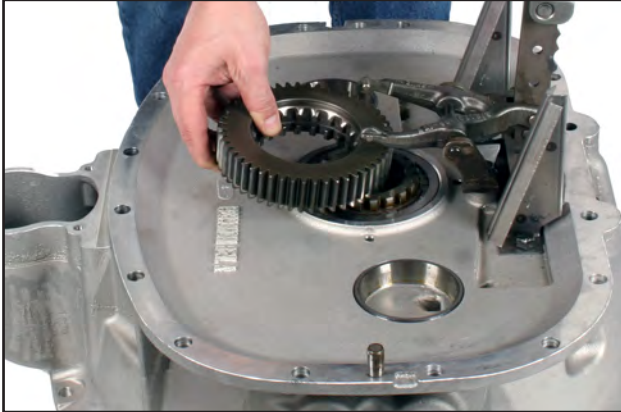


**Step 12:** If the 4th-5th speed shift fork shoes are worn, replace them. It is not necessary to remove the fork to replace the fork shoes.

## Section 8: Main Case Disassembly

### Step-by-Step Procedures

Figure 8.1



**Step 13:** The 5th speed (direct) gear or 4th speed (overdrive) gear is removed next.



**Step 14:** To remove the 4th-5th speed shift fork, remove the snap ring. Push the pin through the bracket. Lift the fork from the unit. Remove the 4th-5th shift fork support brackets.



**Step 15:** Remove the countershaft front bearing cups as shown.



**Step 16:** Inspect O-rings in clutch housing.



**Step 17:** To remove the input shaft and front bearing retainer, remove the four bearing retaining bolts. Pull the shaft from the housing. It may be helpful to place 2 bolts in the threaded bearing retainer holes to remove the front bearing retainer. Tap the input shaft out of the clutch housing.



**Step 18:** To disassemble the input shaft assembly, remove the snap ring. Press the bearing off the shaft.

## Section 8: Main Case Disassembly

### Comparison of Direct Drive/Overdrive Shift Collar

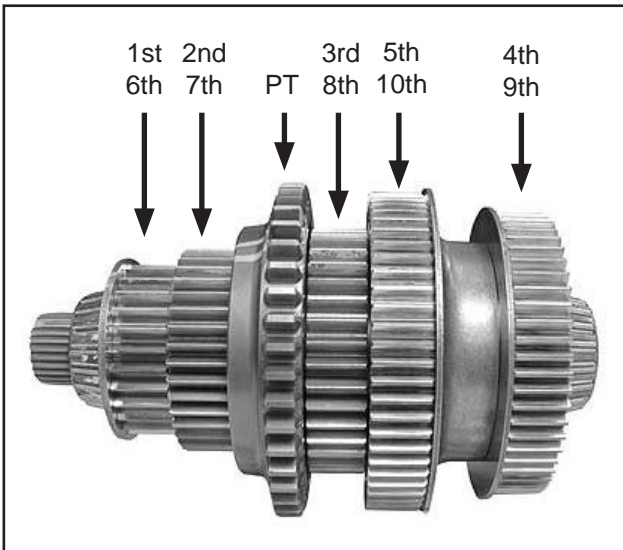
Figure 8.2



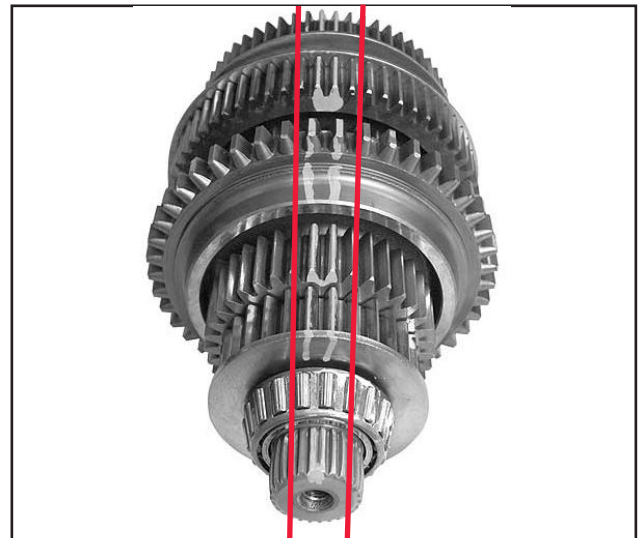
**Step 17:** In an overdrive transmission, notice that the fork slot of the 4th-5th speed shift collar is wider than the fork slot on the other collars. In a direct transmission, all collars will be the same.

## Section 9: Countershaft Disassembly and Reassembly

### Countershaft Views

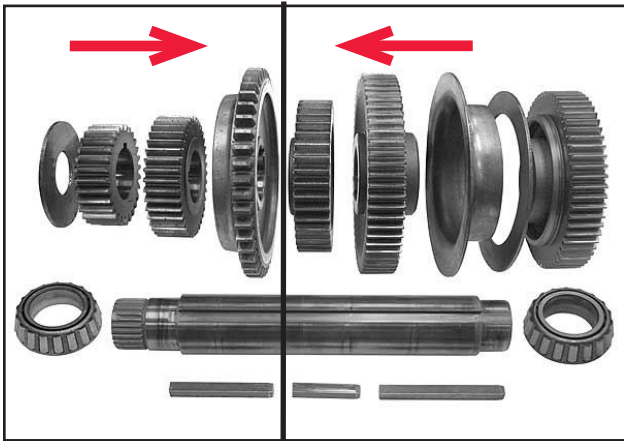


**Figure 9.1:** The countershaft shown here is from an overdrive transmission. In a direct drive transmission, the 4th and 5th gears would be switched. The gears are aligned with a blind spline containing 3 drift keys.



**Figure 9.2:** If a straight edge is placed between the teeth, every gear on the countershaft will be in line with the blind spline on the countershaft. When the shafts are in time, these marks will be perfectly inline with one another.

## Section 9: Countershaft Disassembly and Reassembly



### Pressing Directions


**Figure 9.3:** When pressing the gears onto the countershaft it is very important to assemble in the proper direction. The bearing, gear and thrust ring to the left of the black bar (see photo) are pressed on from one direction; all other items are pressed on from the other direction.


The countershaft components shown here are from an overdrive transmission. In a direct drive transmission, the 4th and 5th gears would be switched. The gears are aligned with a blind spline containing 3 drift keys.


## Section 10: Cleaning and Inspection Procedures

### Cleaning

**Prior to reassembly, wash all parts thoroughly.**

 Use a petroleum-based solvent. Refer to the solvent manufacturer's safety precautions to prevent personal injury or transmission damage.

 Do not use water or steam to clean internal components. If you do, it could cause corrosion of these components.

 Do not use gasoline to clean parts. Gasoline can explode, causing serious physical injury.

Dry the parts immediately with compressed air. Coat them with lubricant if they are to be reassembled immediately. If the parts are to be stored, coat them with a rust inhibitor and wrap them to keep contamination out.

Inspect parts thoroughly for wear or damage. Worn or damaged parts must be replaced to insure maximum rebuild life. Suggested inspection procedures include the following.

### Inspection

#### Clutch Collars

Both the internal and external teeth must have sharp edges. Check for chipped or broken teeth, or teeth with rounded corners. Replace collars if any of these conditions exist.

#### Gears

Examine for broken or cracked operating and clutching teeth. Also check for any unusual wear

patterns. If any of the preceding exists, replace the gear. If a gear is replaced, also replace the mating gear.

#### Thrust Washers

Check for excessive face wear, cracks, scoring, or signs of heat damage. Replace if any of these conditions exists.

#### Snap Rings

New snap rings are recommended with every rebuild.

#### Mainshaft

Check for signs of twisting or misalignment. Also check for worn or damaged splines. Replace the shaft if any of these conditions exists.

#### Remote Shift Control

Check the shift fingers, bushing bores and rods for excessive wear or scuffing. Replace springs, bearing races, boots and seals. Clean all reusable parts thoroughly and apply a light coat of grease to the pivot points when reassembling.

#### Bearings

New bearings are recommended with every rebuild. (See "General Disassembly Bearings" for further information.)

#### Housings

Inspect the housing sections for cracks. If cracks exist, replace that section of the housing. Also inspect the shift bar support bracket for cracks or worn slots. Replace if either of these conditions exists.

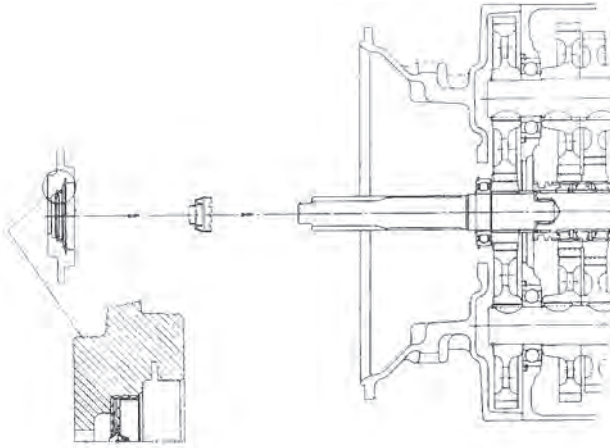
## Section 11: Front Bearing Retainer and Seal Assembly

### Step-by-Step Procedures

Figure 11.1



When installing the front bearing retainer and seal in the transmission, use the red plastic sleeve that comes with the seal kit to prevent serious damage to the oil seal. Failure to use the seal sleeve will void the seal warranty.



#### Steps:

1. Install seal dry into bearing cap assembly.
2. Hydrodynamic lip seal must be installed so that hydrodynamic lip faces inside of transmission.
3. Install red sleeve over end of input shaft.
4. Install bearing cap assembly to the transmission.



## Section 12: Main Case Reassembly

### Step-by-Step Procedures

Figure 12.1



**Step 1:** Install the input shaft. Using a protective sleeve, slide the front bearing retainer into place. Torque the four cap bolts to 34-41 lb-ft.



**Step 2:** Install countershaft O-rings and countershaft bearing cups.



**Step 3:** Install the overdrive and shift fork support bracket. Continue by installing 5th speed (in direct) or 4th speed (overdrive) gear with the thrust face toward the input bearing. The timing marks should be positioned to align with the countershafts.



**Step 4:** Install the 4th-5th speed fork. Secure it with the pin and two snap rings.



**Step 5:** Place the 4th-5th shift collar on the mainshaft and install into fork. Set mainshaft into position.



**Step 6:** Locate the blind spline on rear of countershaft. All gears will align with blind spline, except PTO drive gear.

## Section 12: Main Case Reassembly

### Step-by-Step Procedures

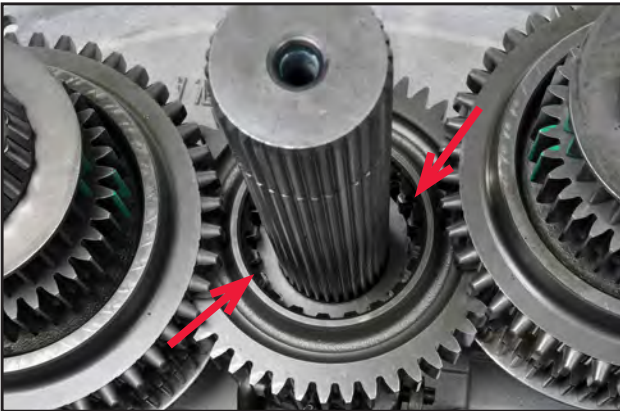
Figure 12.1



**Step 7:** Align timing marks on head-end gear with timing marks on countershaft head-end gear. Leave the countershafts tilted outward, as shown.



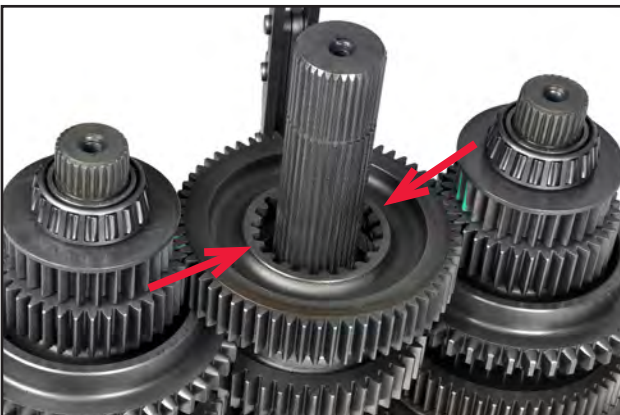
**Step 8:** Slide 3rd gear – clutch teeth up, and 4th gear (direct models)/5th gear (overdrive models) – clutching teeth down, over mainshaft.



**Step 9:** Tilt countershafts inward to engage 3rd and 4th speed gears. Make sure there is equal spacing around the mainshaft and internal teeth on both gears.



**Step 10:** Install 2nd-3rd clutch collar and fork.



**Step 11:** Clutching teeth facing down, slide 2nd speed gear into place between the mating countershaft gears. Make sure to maintain equal spacing around the mainshaft.



**Step 12:** Install 1st speed gear by simultaneously pushing 1st speed gear away from you with your thumbs and pulling back on the countershaft with your fingers until 1st gear drops into place as shown. Clutching teeth facing up.

## Section 12: Main Case Reassembly

### Step-by-Step Procedures

Figure 12.1



**Step 13.** Note the equal spacing around the mainshaft.



**Step 14.** Install the 1st-reverse shift fork and collar. Double check timing by shifting each sliding collar into its mating, or respective, gear.



**Step 15:** Install mainshaft snap ring.



**Step 16:** Install new gasket.



**Step 17:** With the aid of a hoist, lower the main case into position. Install the case bolts and torque them to 78-98 lb-ft.

## Section 13: Range Case Reassembly

### Step-by-Step Procedures

Figure 13.1



**Step 1:** Install the countershaft shims (thin ones first) and retainer plate. Install the 3 retainer plate bolts and torque the bolts to 34-41 lb-ft.



**Step 2:** Place the oil bypass valve into the opening in the main case oil passage. Install the bearing retaining plate and shims. Torque the 4 retainer plate bolts to 34-41 lb-ft.



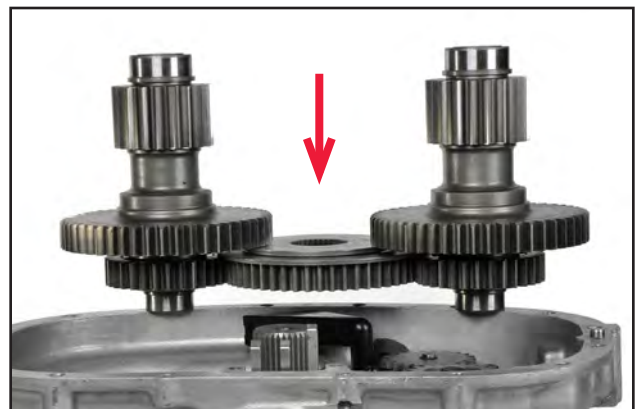
**Step 3:** Check the main box countershaft end play. Verify that end play is between .001-.003 on each countershaft; adjust shims accordingly.



**Step 4:** Install the Opti-Lube™ pump on the bearing retaining plate. Secure the unit with the 2 bolts and torque to 34-41 lb-ft. Spin the Opti-Lube pump gear to ensure that it spins freely.



**Step 5:** Install the countershaft reverse gears. These gears only fit in one position because of the blind spline. Secure each gear with a washer and bolt. Torque bolts to 78-98 lb-ft.

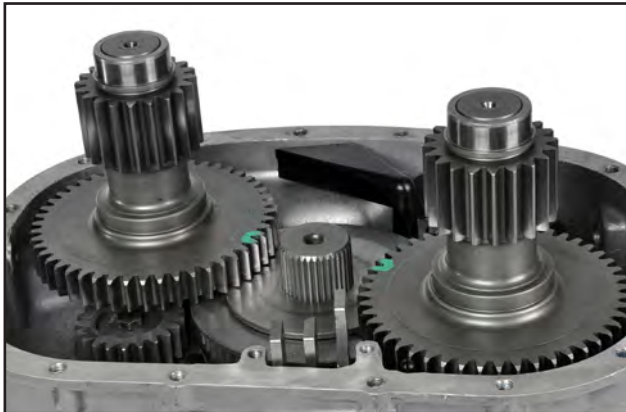


**Step 6:** Position the reverse gear and the thrust plate between the range countershaft gears.

## Section 13: Range Case Reassembly

### Step-by-Step Procedures

Figure 13.1



**Step 7:** Slide the countershaft and reverse gear assembly down over the mainshaft.



**Step 8:** Be sure to align the timing marks as the high range gear is installed.



**Step 9:** Install the rear shift fork support bar. Torque the 2 bolts to 34-41 lb-ft.



**Step 10:** Install the high range clutch gear and the synchronizer cup. Secure with washer and bolt. Torque to 78-98 lb-ft.



**Step 11:** Install the range synchronizer and range fork with the synchronizer springs facing toward the output yoke or flange.



**Step 12:** Install new gasket.

## Section 13: Range Case Reassembly

### Step-by-Step Procedures

Figure 13.1



**Step 13:** Install the output shaft assembly into the range case. The tapered bearing and spacer must be pressed onto the shaft.



**Step 14:** With the use of a hoist, lower the range case into place. Low range gear should be centered between the countershafts. Torque the case bolts to 78-98 lb-ft.



**Step 15:** Install rear auxiliary countershaft bearings into range case. The rear bearing retainer is installed next. To shim the retainer, measure the depth from the edge of the case to the bearing cup (Distance A).



**Step 16:** Measure the height of the lip on the rear bearing retainer (Distance B). Subtract the two figures and shim accordingly. Tolerance is .001 - .004. Select shims accordingly so the tolerance is closest to .001 as possible.



**Step 17:** Install speed gear, shims and rear bearing retainer. Be sure to use sealant on the rear bearing retainer. Secure with bolts tightened to 34- 41 lb-ft.



**Step 18:** Install the bearing retainers with sealant. Align the bearing retainers with the oil holes in the case to ensure proper lubrication. Torque bolts to 34-41 lb-ft.

## Section 13: Range Case Reassembly

### Step-by-Step Procedures

Figure 13.1



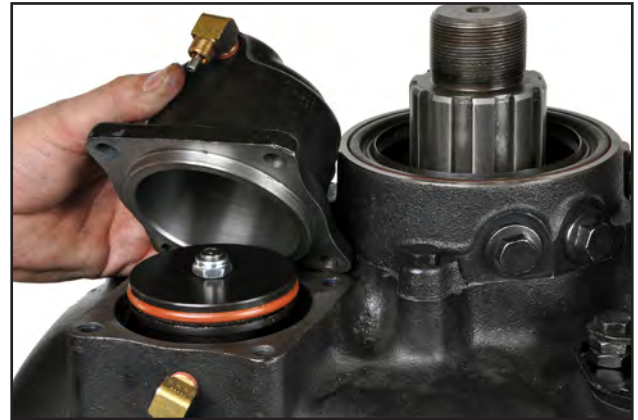
**Step 19:** Assemble two spacers under the air filter regulator. The two air filter regulator bolts are longer than the other six bearing retainer bolts. Torque to 34-41 lb-ft.



**Step 20:** Lubricate and install new O-rings on the piston; install the piston. The counterbore on the piston should face the new O-ring on the range fork shaft.



**Step 21:** Install the retaining nut and torque to 52-62 lb-ft. Lubricate the piston O-ring.



**Step 22:** With the air inlet at the top, install the range piston housing with four bolts. Torque to 34-41 lb-ft.



**Step 23:** Using a hoist, place the transmission in a horizontal position. Install the two mechanical clutch housing retainer bolts (4 in hydraulic units). Torque to 78-98 lb-ft. Bench shift transmission to ensure it is working correctly.



**Step 24:** Install air control valve gasket, the backup light switch and pin.

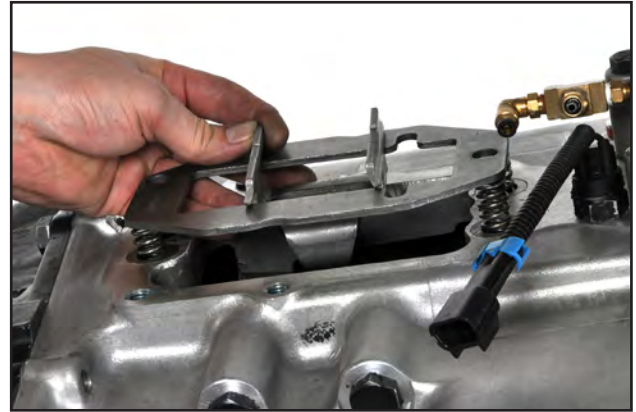
## Section 13: Range Case Reassembly

### Step-by-Step Procedures

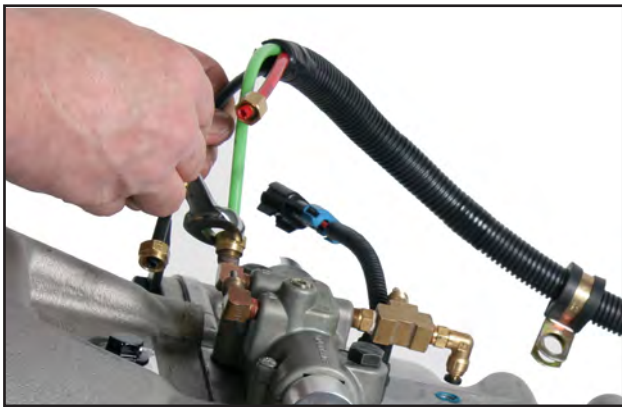
Figure 13.1



**Step 25:** Shift all forks into neutral; install the three air control valve pins and the air control valve. Torque the two retaining bolts to 52-62 lb-ft.



**Step 25:** Insert three poppet balls and springs into case. Place the interlock into the interlocking retaining plate and install the assembly. Adjust to the proper position for a forward or center control. Secure the plate with two bolts and torque to 52-62 lb-ft.



**Step 26:** Using a wrench, install the air lines (refer to air line schematic). To modify the length of the air lines, use a razor-sharp edge to cut the tubing squarely. Never use side cuts.



**Step 17:** Reassembly is complete with the installation of the shift tower gasket and shift tower.



The gasket must be in place to ensure proper gear selection. If this gasket is eliminated, binding may occur (the gasket also acts as a shim).



Do not apply sealant to the shift tower or housing as this may prevent proper interlock functioning. Torque bolts to 31-45 lb-ft.



## Section 14: Remote Shift Control Reassembly

### Step-by-Step Procedures

Figure 14.1

**Step 1:** After packing the remote control housing cavity with grease, install the rod.

**Step 2:** Set the shift finger in place and secure with a setscrew. Torque to 40-50 lb-ft.

**Step 3:** Slide the boot over the rod onto the remote control housing. Secure with two tie-down straps.

**Step 4:** Put the outer shaft lever onto the splined end of the shift rod. Install the setscrew and torque to 40-50 lb-ft.

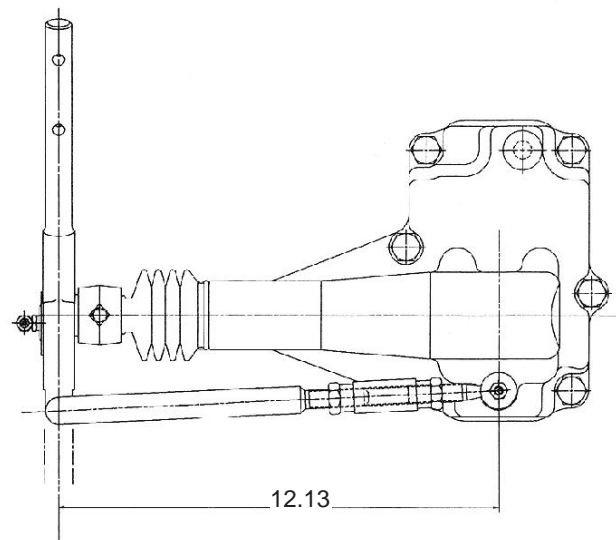
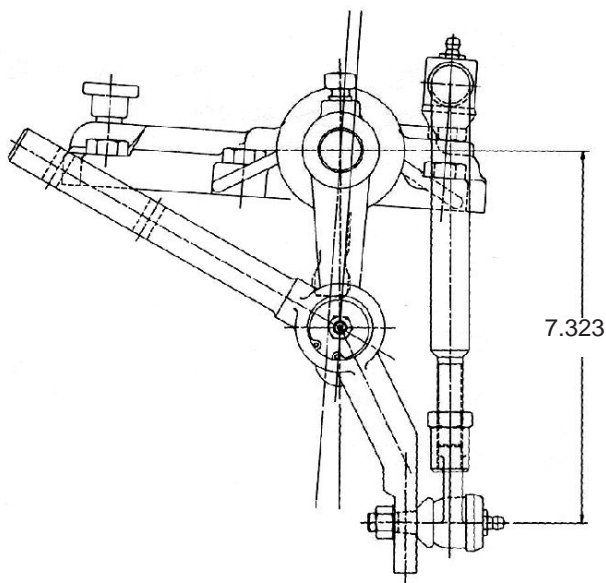
**Step 5:** Reassemble the selection lever subassembly and bolt into place.

**Step 6:** Screw the jam nuts, turnbuckle and ball joints onto the tie rod. Grease the ball joints.

**Step 7:** Place a spacer on the ball joint studs. Attach it to the selection lever subassembly and remote control housing. Place the interlock in the rear position and install the interlock.

**Step 8:** Install the new remote control gasket and assembly onto the transmission. Torque to 31-45 lb-ft. Adjust the linkage according to the original equipment manufacturer's specifications.

**Step 9:** Check the remote control dimensions shown in Figure 12.1.



## Section 15: Shift Tower Reassembly

### Step-by-Step Procedures

Figure 15.1

**Step 1:** Place the two opposing springs and the outer ring into the shift tower.

**Step 2:** Place the lever through the tower and support it in a vise.

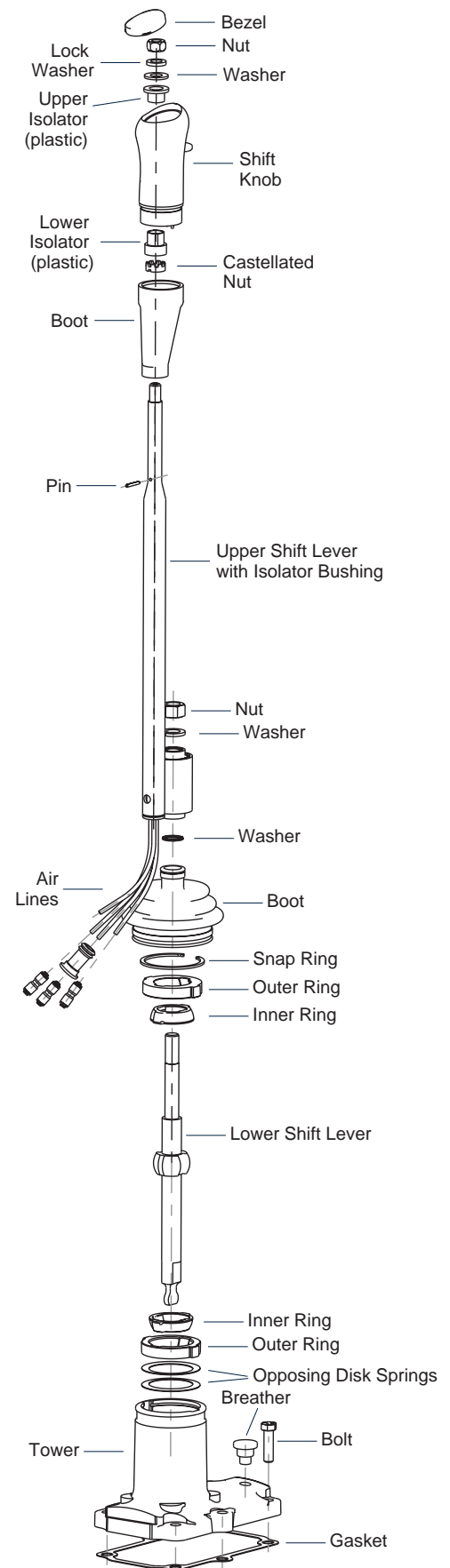
**Step 3:** Install the outer ring. Once the outer ring clears the groove, install the snap ring.

**Step 4:** Seat the boot properly and secure it with two tie-down straps.



**Step 5:** When the tower is installed onto the transmission housing, one single gasket must be in place under the tower assembly for proper gear selection.

Failure to use a gasket or using more than one gasket under the tower may cause binding and damage to the unit.



## Section 16: Troubleshooting

---

### Noisy Operation

Noise is usually a very elusive problem, and is generally not the fault of the transmission. Technicians should road test the vehicle to determine if the driver's complaint of noise is actually in the transmission.

In numerous instances where drivers have insisted noise was coming from the transmission, investigations revealed it was caused by one of the following conditions:

1. Fan out of balance or blades bent.
2. Defective vibration dampers.
3. Crankshaft out of balance.
4. Flywheel out of balance.
5. Loose flywheel mounting bolts.
6. Rough engine idle producing rattle in gear train.
7. Clutch assembly out of balance.
8. Loose or broken engine mounts.
9. Power take-off engaged.
10. Worn universal joints.
11. Driveshaft out of balance.
12. Universal joint angles out of phase or at excessive angles.
13. Center bearings in driveline dry, not mounted properly.
14. Wheels out of balance.
15. Tire treads humming or vibrating at certain speeds.
16. Air leaks on suction side of induction system, especially with turbo-chargers.

Technicians should try to locate and eliminate noise by means other than a transmission removal or an overhaul. However, if the noise appears to be in the transmission, try to determine what position the gear shift lever is in when the noise occurs. If the noise is evident in only one gear position, the problem is generally traceable to the operating gears. Next, try to categorize the noise into the following classifications:

**(A) Growling, humming and grinding.**

These noises are caused by worn, chipped, rough or cracked gears. As gears continue to wear, the grinding noise will be noticeable particularly in the gear position that throws the greatest load on the worn gear. A lack of lubricant or use of improper lubricant can also result in growling and

grinding noises. This is because there is insufficient lubricant to cool and cover the gears, which allows metal-to-metal contact.

**(B) Hissing, thumping and bumping.**

Hissing noises can be caused by bad bearings. As bearings wear and retainers start to break up, etc., the noise could change to a thumping or bumping.

**(C) Gear whine.** This is usually caused by lack of backlash between mating gears. Improper PTO shimming is the big offender here.

**(D) Vibration.** Today's improved highways mean entire power trains are cruising at higher RPM's. These higher speeds mean damage caused by driveline vibration is more obvious than in the past. When the maximum RPM of a shaft is reached, it begins to bow. A resonant hum can be heard, and a vibration will be felt. This type vibration can cause gear seizures, broken synchronizer pins, bearing failures, brinelling and corrosion. During acceleration and deceleration, the shaft may pass through half-critical vibration (half the maximum RPM of the shaft). A whine or boom may be heard at this point.

**(E) Metallic rattles.** These noises within the transmission usually result from a variety of conditions. Engine torsional vibrations are transmitted to the transmission through the clutch. In heavy duty equipment, clutch discs with vibration dampers are not used, so a rattle - particularly in neutral - is common with diesel equipment. In general, engine speeds should be 600 RPM or above to eliminate objectionable rattles and vibration during the idle. A defective or faulty injector would cause a rough or lower idle speed, and possibly a rattle in the transmission. A rattle can also be caused by excessive backlash between the PTO input gear and the transmission output gear.

## Section 16: Troubleshooting

---

### Noise in Neutral

#### *Possible Causes:*

1. Misalignment of transmission.
2. Worn flywheel pilot bearing.
3. Worn or scored countershaft bearings
4. Sprung or worn countershaft.
5. Excessive backlash in gears.
6. Scuffed gear tooth contact surface
7. Insufficient lubrication.
8. Use of incorrect grade of lubricant.

### Noise In Gear

#### *Possible Causes:*

1. Rough, chipped, or tapered sliding gear teeth.
2. Noisy speedometer gears.
3. Excessive end play of countershaft gears.
4. Refer to conditions listed under "Noise in Neutral."

### Oil Leaks

#### *Possible Causes:*

1. Oil level too high.
2. Wrong lubricant in transmission.
3. Seals defective, wrong type or omitted from bearing cap.
4. Transmission breather omitted or plugged internally.
5. Capscrews loose, omitted or missing from remote control, shifter tower, bearing caps, PTO or covers.
6. Oil drain-back openings in bearing caps and/or case plugged with varnish or dirt.
7. Gaskets shifted or squeezed out of position, broken gaskets with pieces still under the shift tower.
8. Cracks or holes in castings.
9. Loose drain plug.
10. Oil leakage from engine.
11. Loose speedometer adaptor or connections.

### Walking or Jumping Out of Gear

*If the unit walks out of gear, it could be caused by:*

1. External interference, such as the floorboard opening, preventing full engagement, or
2. An internal malfunction, such as worn clutching teeth, allowing the transmission to shift out of position.

If a remote control is being used, make sure it is functioning properly before the transmission is blamed for the problem. Note whether the unit walks out of gear under drive while pulling a load, or when coasting. Also, notice whether the gear hop occurs on smooth roads or only on rough roads. Items that would prevent full engagement of gears are:

3. Improperly positioned forward remote control which limits full travel forward and backward from the neutral position.
4. Improper length shift rails or linkage that limits travel of forward remote from neutral position.
5. Loose bell cranks, sloppy ball and socket joints.
6. Shift rails, cables, etc., too spongy or flexible, or not secured properly at both ends.
7. Worn or loose engine mounts if forward unit is mounted to frame.
8. Forward remote mount too flimsy, or loose on the frame.
9. Setscrews loose at remote control joints, on shift forks inside remote.
10. Shift fork pads or groove sliding gear or collar worn excessively.
11. Transmission and engine out of alignment either vertically or horizontally. A few items which could move the gear or shaft out of proper position, particularly on rough roads are:
  - (a) Use of heavy shift lever extensions.
  - (b) Broken shift rail poppet springs.
  - (c) Worn shift rail poppet notches.
  - (d) Bent or sprung shift rails.
  - (e) Excessive end-play in drive gear or countershaft, caused by worn bearings or retainers.
  - (f) Worn or missing thrust rings.

## Section 16: Troubleshooting

### Hard Shifting

An improperly operating clutch will interfere with the proper shifting of gears in any transmission. It is also important that the hydraulic, air or similar release mechanism is in proper working order. If full and complete clutch release is being made, the following could be a few of the possible causes for hard shifting complaints:

1. No lubricant in remote control unit. (Note: The forward remote is isolated and is often overlooked. Many remote controls used on transmissions and auxiliaries require separate lubrication.)
2. No lubrication in, or grease fittings on, u-joints or swivels of remote controls.
3. Lack of lubricant or wrong lubricant used, causing buildup of sticky varnish and sludge deposits on splines of shaft and gears.
4. Badly worn or bent shift forks.
5. Improper adjustment on shifter linkage.
6. Sliding clutch gears tight on splines of shaft.
7. Clutch teeth burred over and chipped or badly mutilated because of improper shifting,
8. Binding or interference of shift lever with other objects or rods inside the cab or near the remote control island.
9. Clutch dragging.
10. Free running gears seized or galled on either the thrust face or diameters.



### Sticking in Gear

*Possible Causes:*

1. Clutch not releasing. Also check remote units such as a hydraulic or air assist. Note: On some units employing a full air control for clutch release, air pressure of approximately 60 lbs. or more must be secured before the clutch can be released. Do not leave these vehicles parked in gear.
2. Sliding clutch gears tight on splines.
3. Chips wedged between or under splines of shaft and gear.
4. Improper adjustment, excessive wear or lost motion in shifter linkage.

### Sticking in Gear

The service life of most transmissions, main and auxiliary, is governed by the life of the bearings. The majority of bearing failures can be attributed to vibration and dirt. Some other prominent reasons for unit bearing failures are:

1. Fatigue of raceways or balls.
2. Wrong type or grade of lubricant.
3. Lack of lubricant.
4. Broken retainers, brinelled races and fretting caused by vibration.
5. Bearings set up too tight or too loose.
6. Improper installation resulting in brinelled bearings.
7. Improper fit of shafts or bore.
8. Acid etching due to water in lube.
9. Vehicle overload or too large an engine for the transmission resulting in overload.

### Dirt

More than 90% of all ball bearing failures are caused by dirt, which is always abrasive.

Dirt may enter the bearings during assembly of units, or may be carried into the bearing by the lubricant while in service. Dirt also may enter bearings through seals, the breather or even dirty containers used for addition or change of lubricant.

Softer material, such as dirt or dust, usually forms abrasive paste or lapping compounds within the bearings. The pressure between the balls and raceways makes a perfect pulverizer: The rolling motion tends to entrap and hold the abrasives. As the balls and raceways wear, the bearings become noisy. The lapping action tends to increase rapidly as the fine steel from the balls and rollway adds to the lapping material.

Hard, coarse material, such as metal chips, may enter the bearings during assembly from tools such as hammers, drifts, and power chisels. It may also be created within the unit during service from raking teeth. These chips produce small indentations in balls and races. When these hard particles jam between the balls and races, it may cause the inner race to turn on the shaft, or the outer race to turn in the housing.

### Fatigue

All bearings are subject to fatigue and must be replaced eventually. Your own operating experience will dictate mileage replacement of bearings showing only normal wear.

## Section 16: Troubleshooting

---

### Corrosion

Water, acid and corrosive materials formed by deterioration of lubricant, will produce a reddish-brown coating and small etched holes over outer and exposed surfaces of the race. Corrosive oxides also act as lapping agents.

### Shaft Fits

Bearing fits on rotating shafts are usually specified as tight. Excessive looseness - even .001" - under a load, produces a creeping or slipping of the inner race on the rotating shaft. The result is that surface metal of the shafts scrub or wear off. The force causing the inner race to rotate disappears when the bearing fits properly.

### Installation and Removal of Bearings

Improper installation or removal of bearings, especially hammering the bearing on the shaft with off-center blows, can result in brinelling. Since such damage is seldom visible, it does not become known until after failure or complete disassembly. The correct drivers (preferably under an arbor press) and pullers should be used.

Removing bearings is more difficult than installing them. In most cases, it is necessary to remove the bearing by pulling on the outer race, which can damage the balls or races. Therefore, it is a good idea to replace bearings during an overhaul, to prevent problems. However, if a bearing is not going to be replaced, avoid removal during low mileage rebuilds.

### Interchangeability

All ball bearings, whether manufactured here or abroad, are interchangeable in regard to standardized dimensions, tolerances, and fits. However, for a given shaft size there are standard bearings for light, medium, and heavy duty service.

Numbers and symbols stamped on inner and outer races of bearings designate size and type. Note that the numbering systems of different bearing manufacturers have not been standardized. Consult interchangeable tables and use the proper bearings for replacement parts.

### Clutch Troubleshooting

Faulty clutch operation interferes with proper shifting of gears in any transmissions. The two following paragraphs describe the most common problems encountered with clutches.

1. If the clutch slips or does not engage properly, first check the internal clutch adjustment. If adjustment does not remedy the situation, check for weak pressure springs, lack of free pedal, and worn or oily clutch facings and binding release mechanism.
2. If the clutch drags or does not release properly, check the internal clutch adjustment. Some other causes for clutch drag are: an intermediate plate sticking on drive pins or drive lugs; the pressure plate not retracting; a distorted or warped driven disc; worn splines on the main drive gear of the transmission; a damaged clutch release bearing; or the bushing in the release sleeve dragging on the transmission drive gear.

### Backup Lights

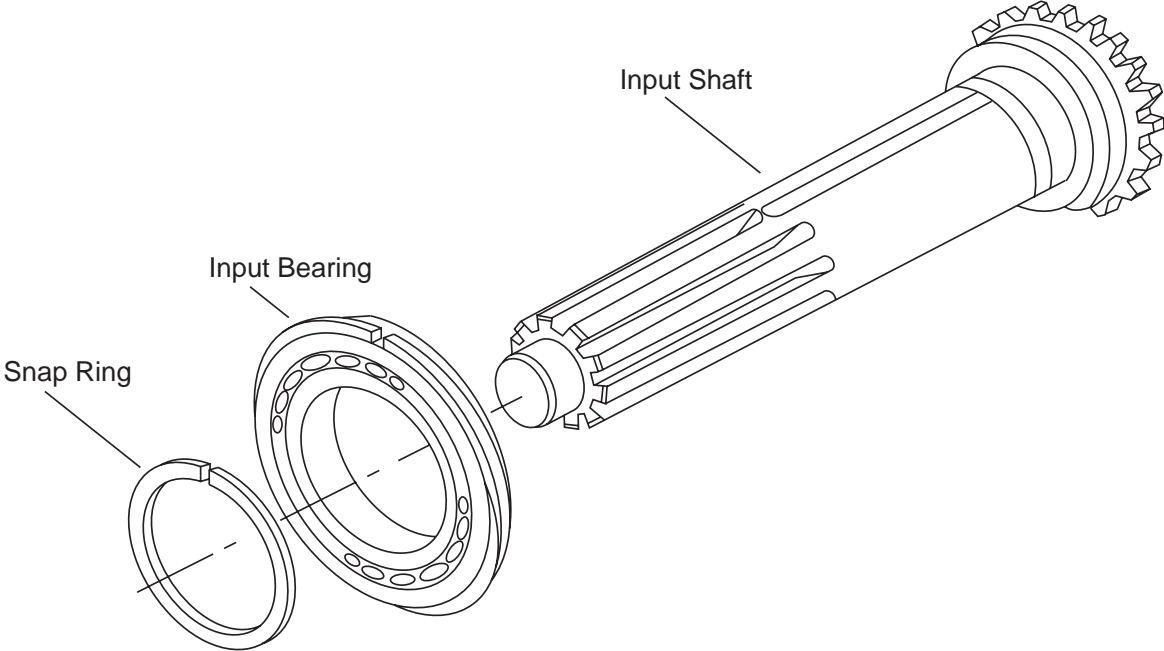
If the backup lights do not function, check the following:

1. Continuity of the switch with the ball fully depressed.
2. Electrical plug connection
3. Wiring

**Section 17: Component Drawings**

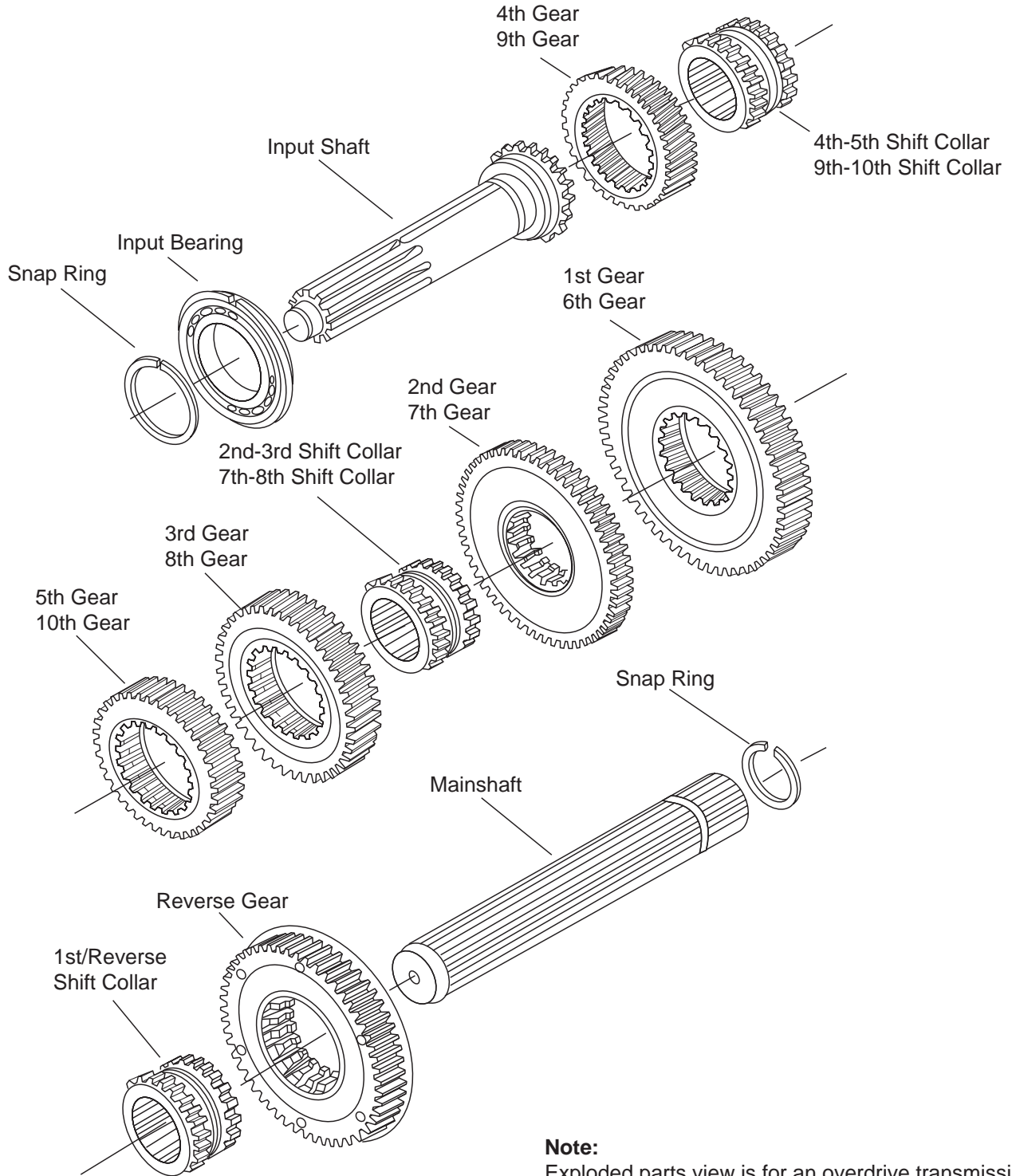
**Input Shaft Group**

Figure 17.1



## Section 17: Component Drawings

### Main Shaft; Primary Gear Group Figure 17.2



**Note:**  
Exploded parts view is for an overdrive transmission.  
For a direct drive transmission, the head gear and  
the overdrive gear are in the opposite position.



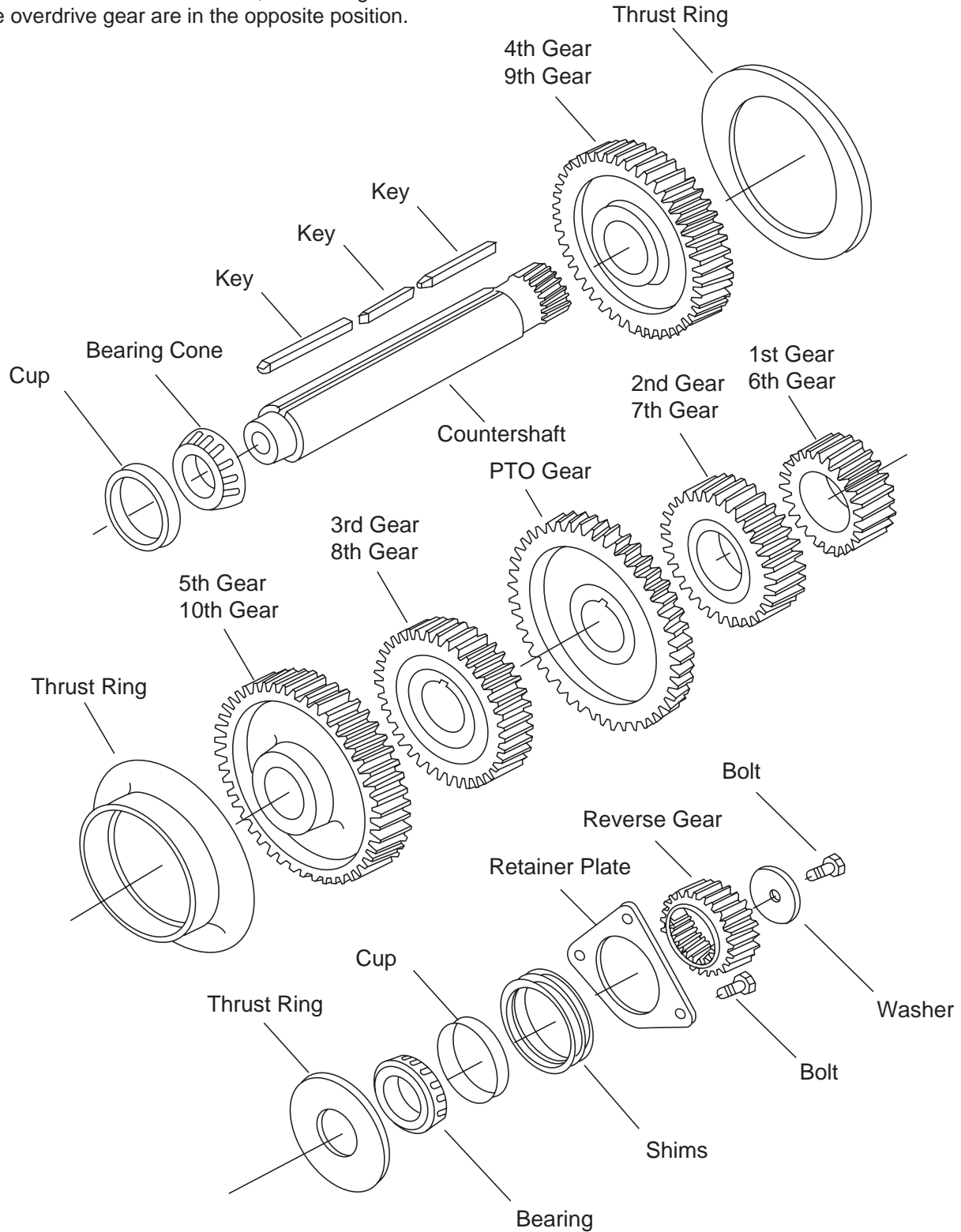
## Section 17: Component Drawings

### Countershaft Gears

Figure 17.3

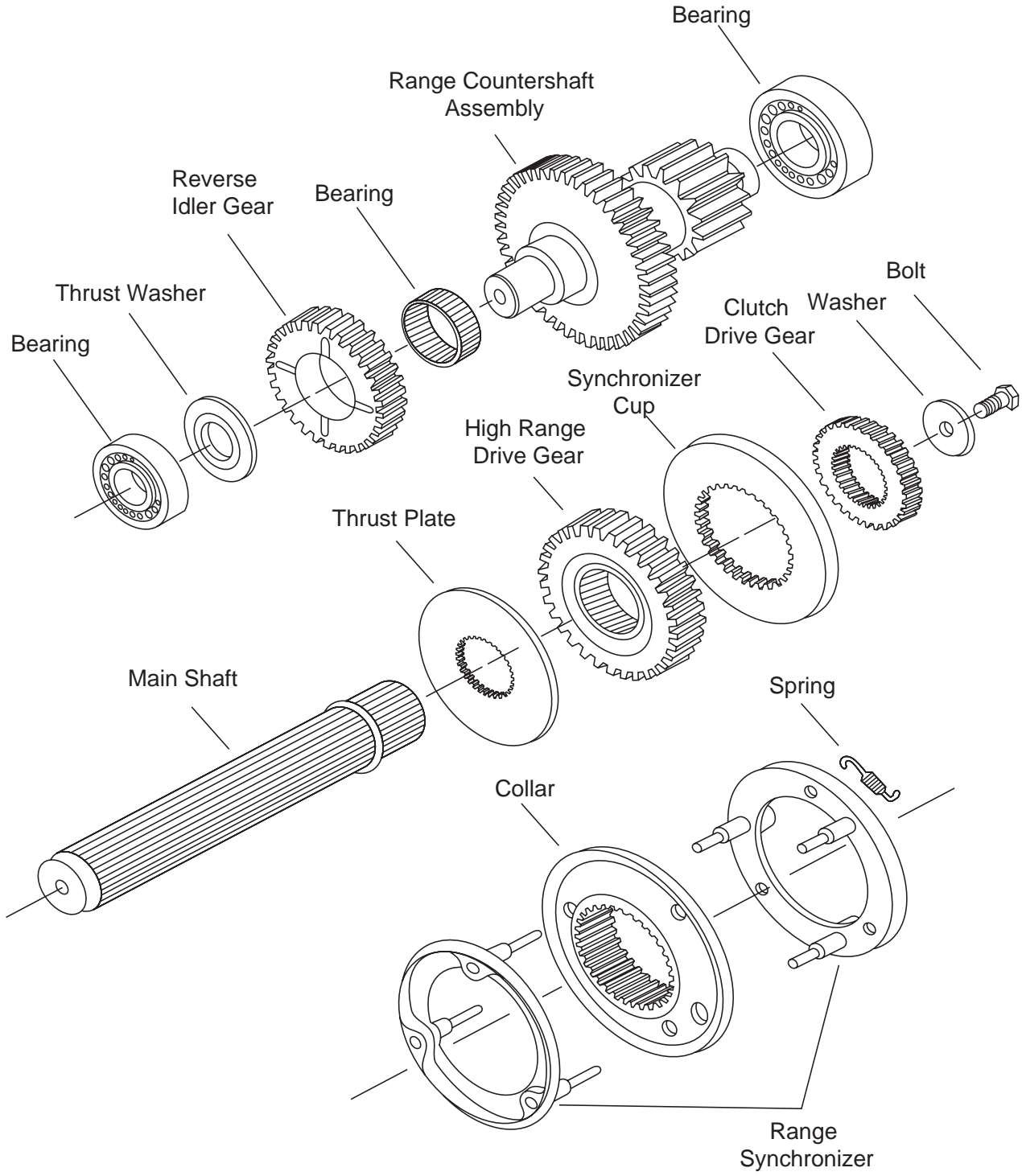
**Note:**

Exploded parts view is for an overdrive transmission.  
For a direct drive transmission, the head gear and the overdrive gear are in the opposite position.



## Section 17: Component Drawings

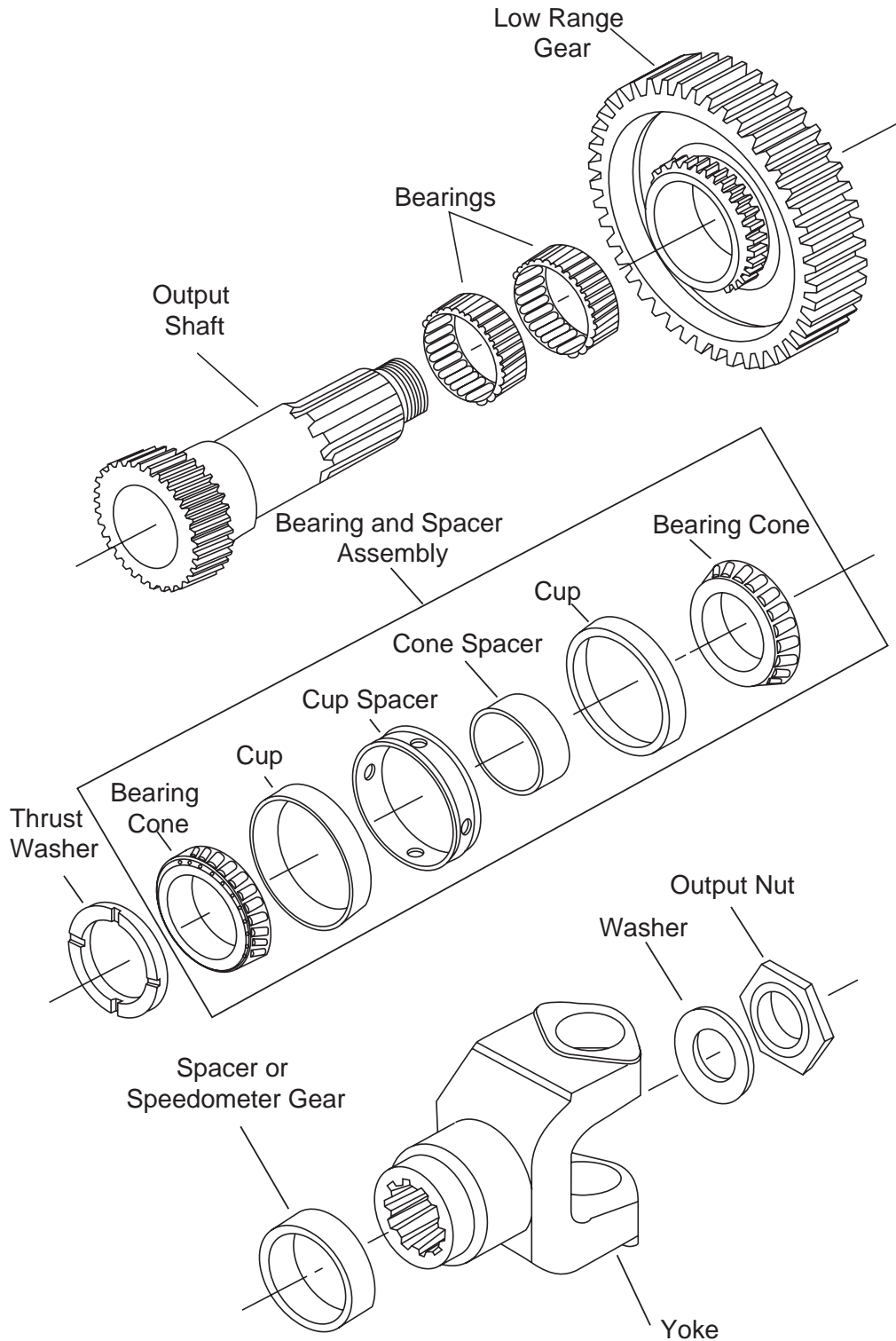
### Range Case Gears Figure 17.4



## Section 17: Component Drawings

### Range Case Gears

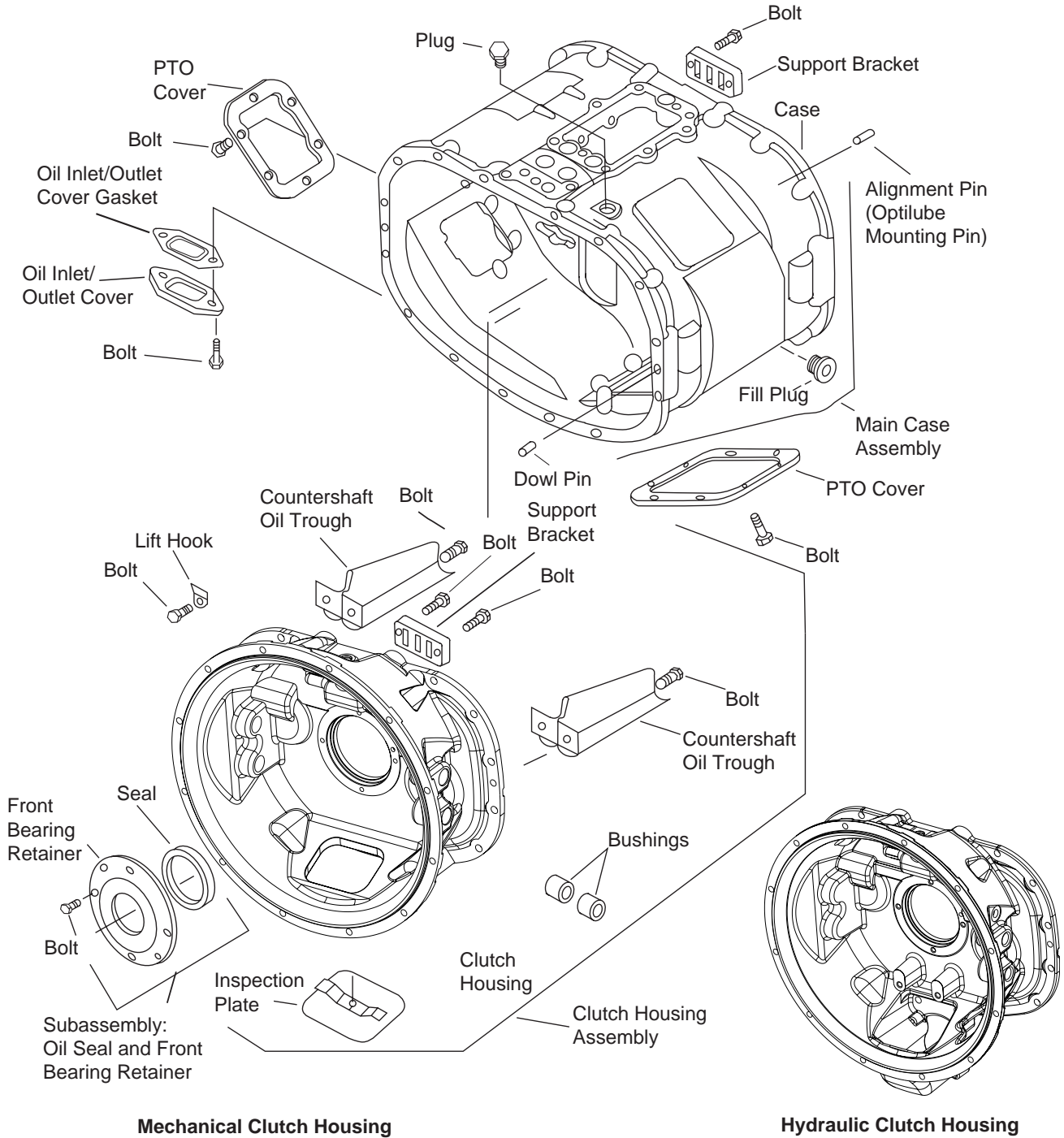
Figure 17.5



# Section 17: Component Drawings

## Main Case and Clutch Housing

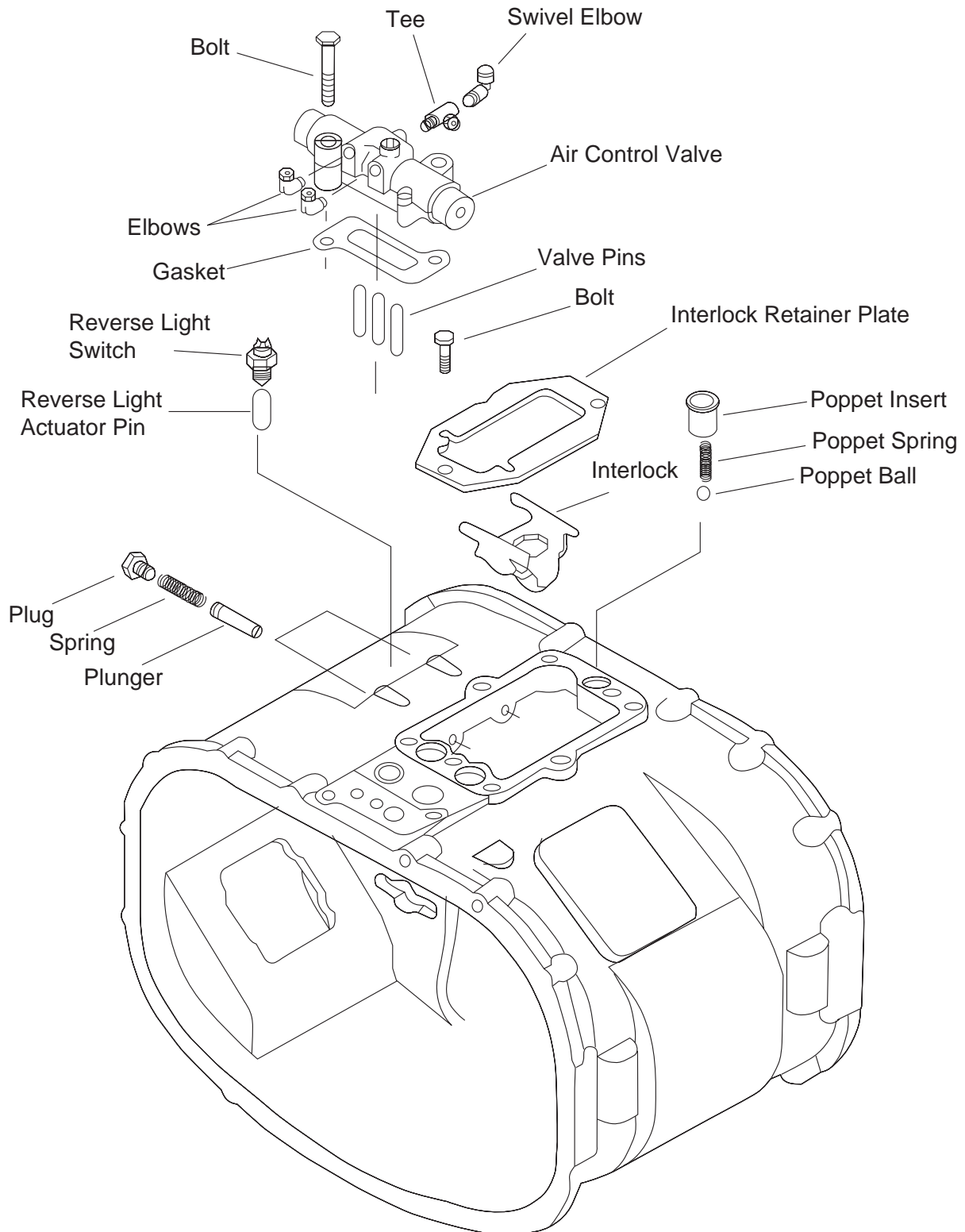
Figure 17.6



## Section 12: Component Drawings

### Air Control Valve

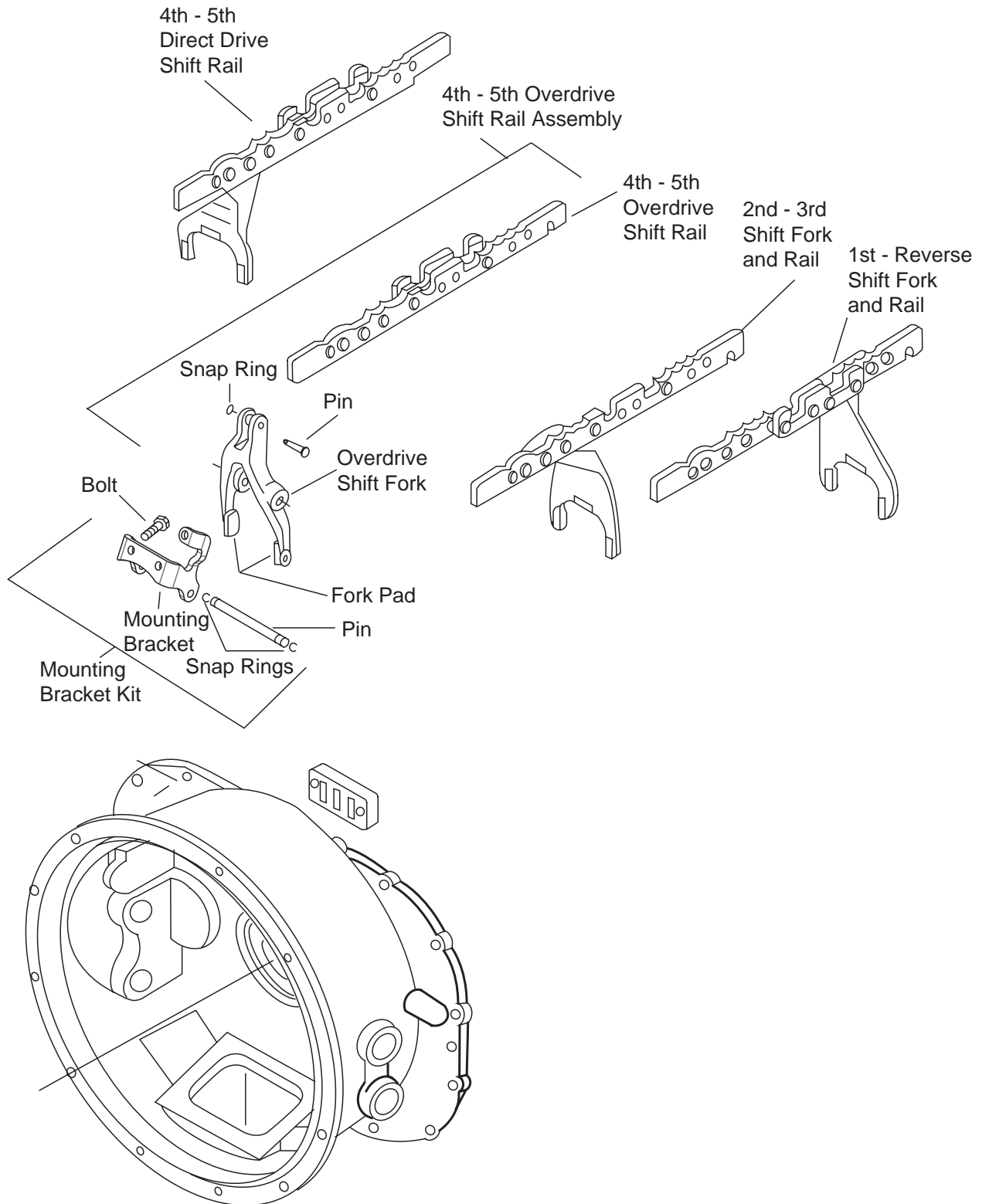
Figure 17.7



## Section 17: Component Drawings

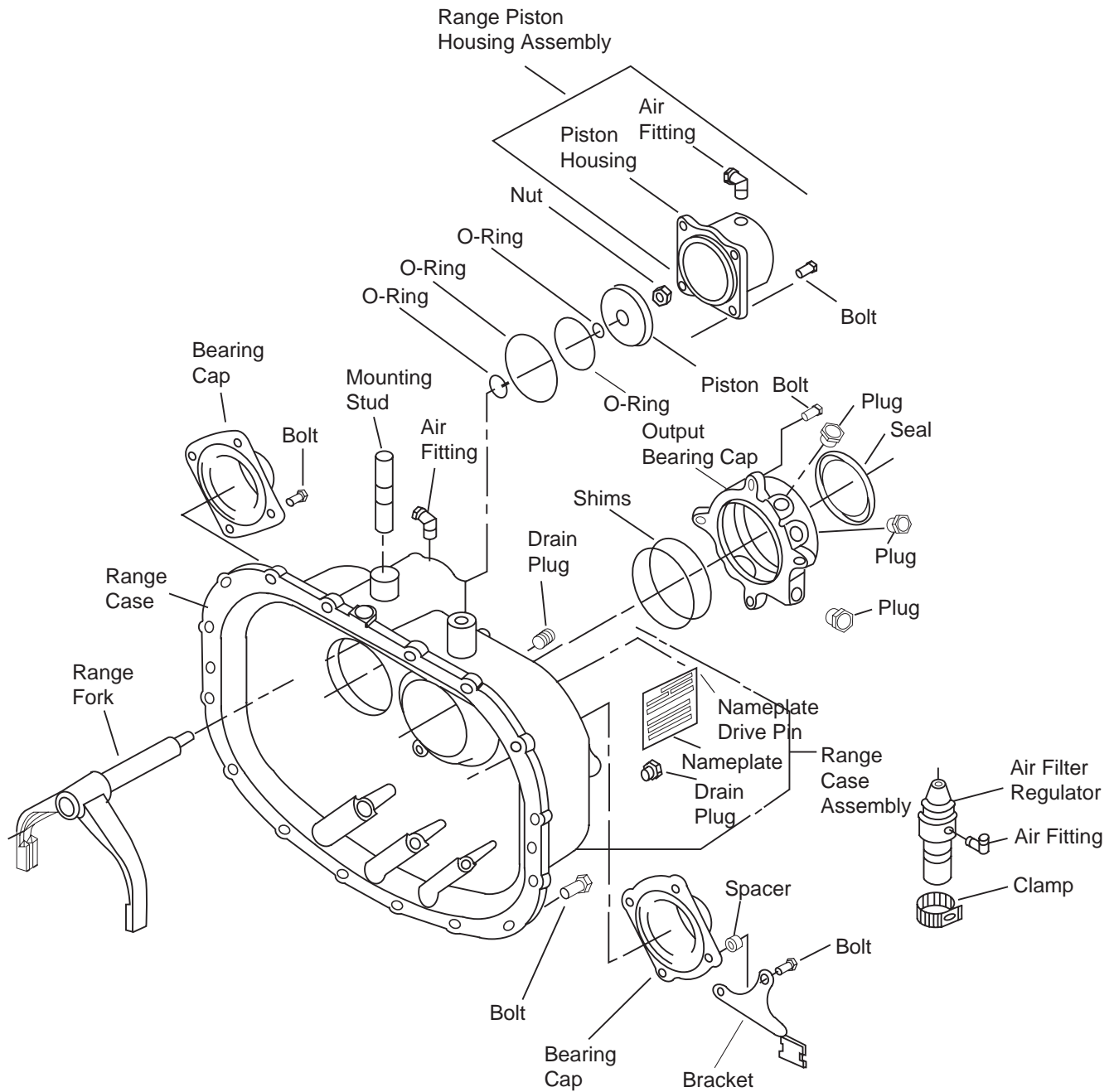
### Fork and Rail Group

Figure 17.8



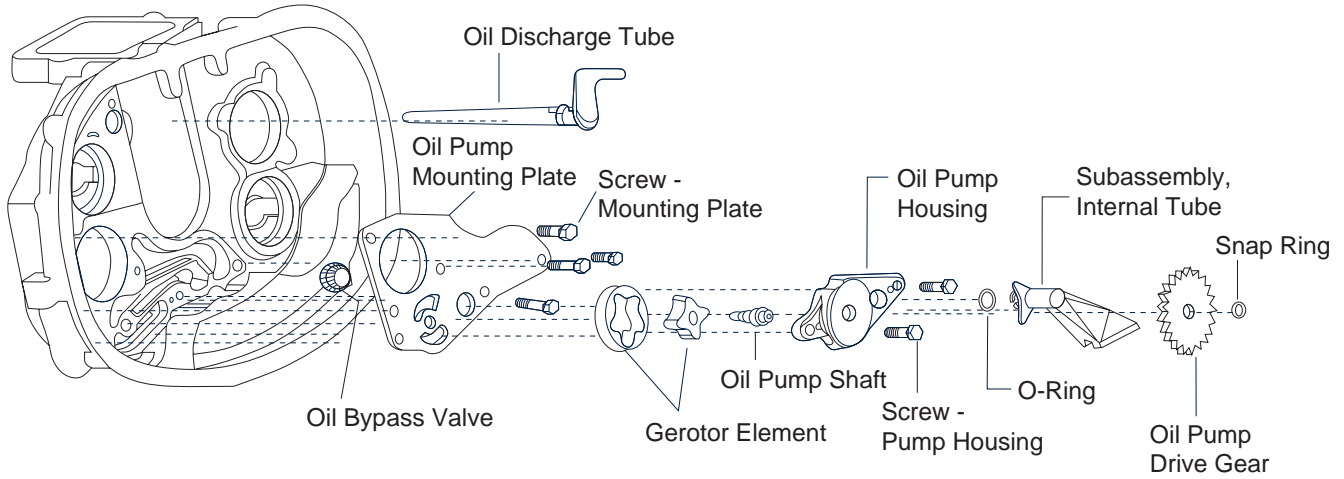
# Section 17: Component Drawings

## Range Case Figure 17.9



## Section 17: Component Drawings

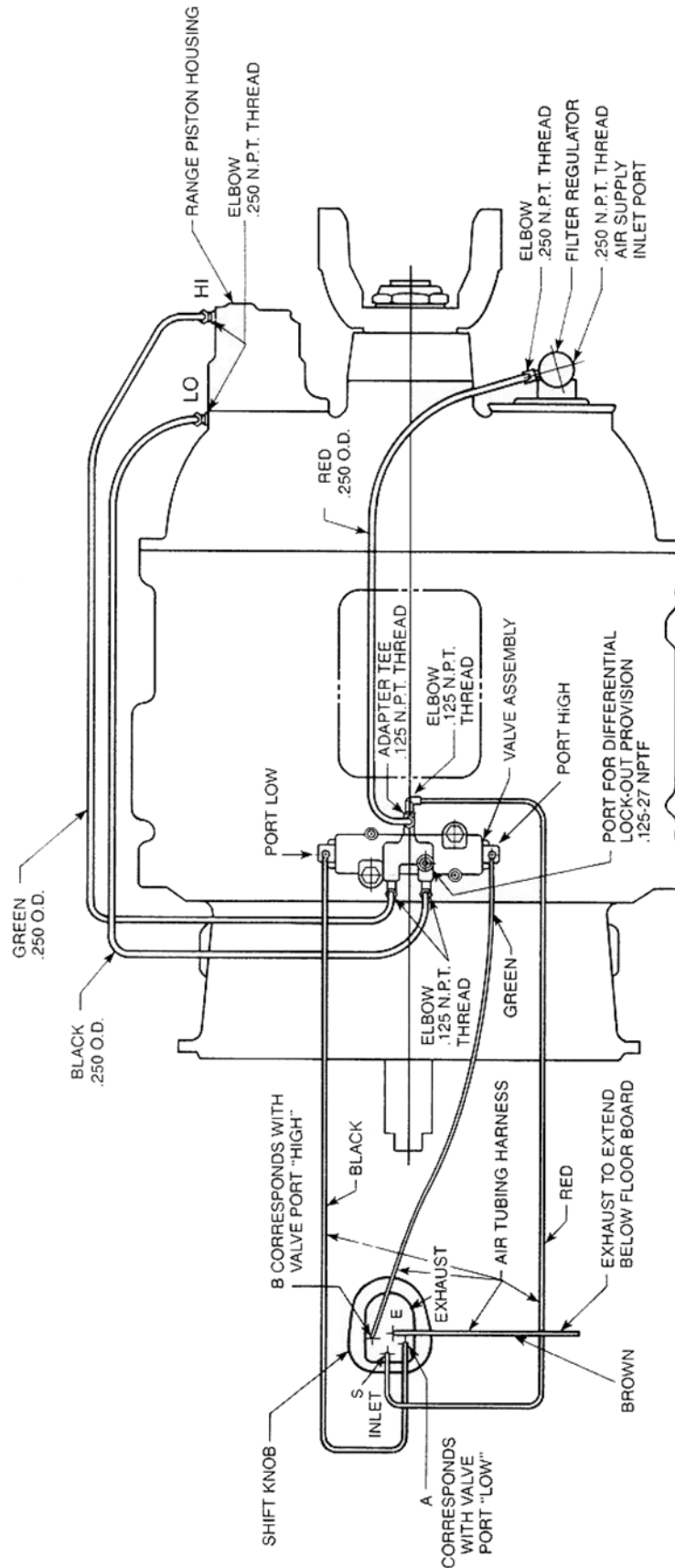
### Main Case - Opti-Lube™ Figure 17.10





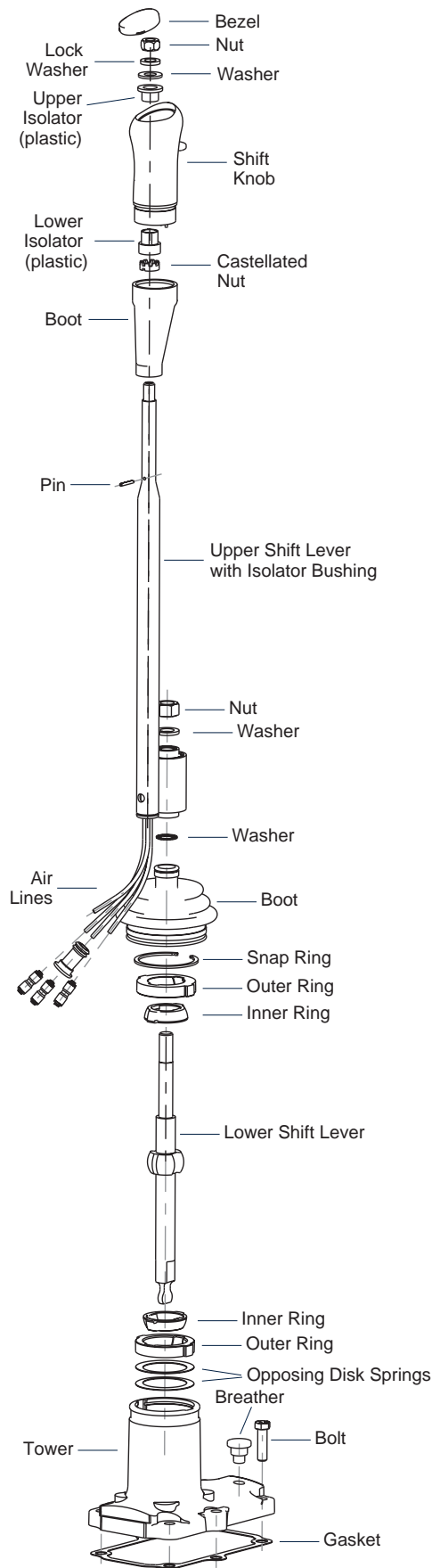
# Section 17: Component Drawings

## Air Line Schematic Figure 17.11



# Section 17: Component Drawings

## Shift Tower Figure 17.12





**TREMEC**<sup>®</sup>

Torque Transfer Solutions<sup>™</sup>

14700 Helm Ct. | Plymouth, MI 48170 U.S.A.  
U.S. Toll Free: (800) 401-9866  
Outside of U.S. (734) 456-3700  
Fax: (734) 456-3739  
[www.tremec.com](http://www.tremec.com)