

# **SPICER®**

WEATHERLY INDEX 084

T210-CM49

August 1988

Supersedes T-210-CM49

Dated August 1986

CM49 Series

Parts List

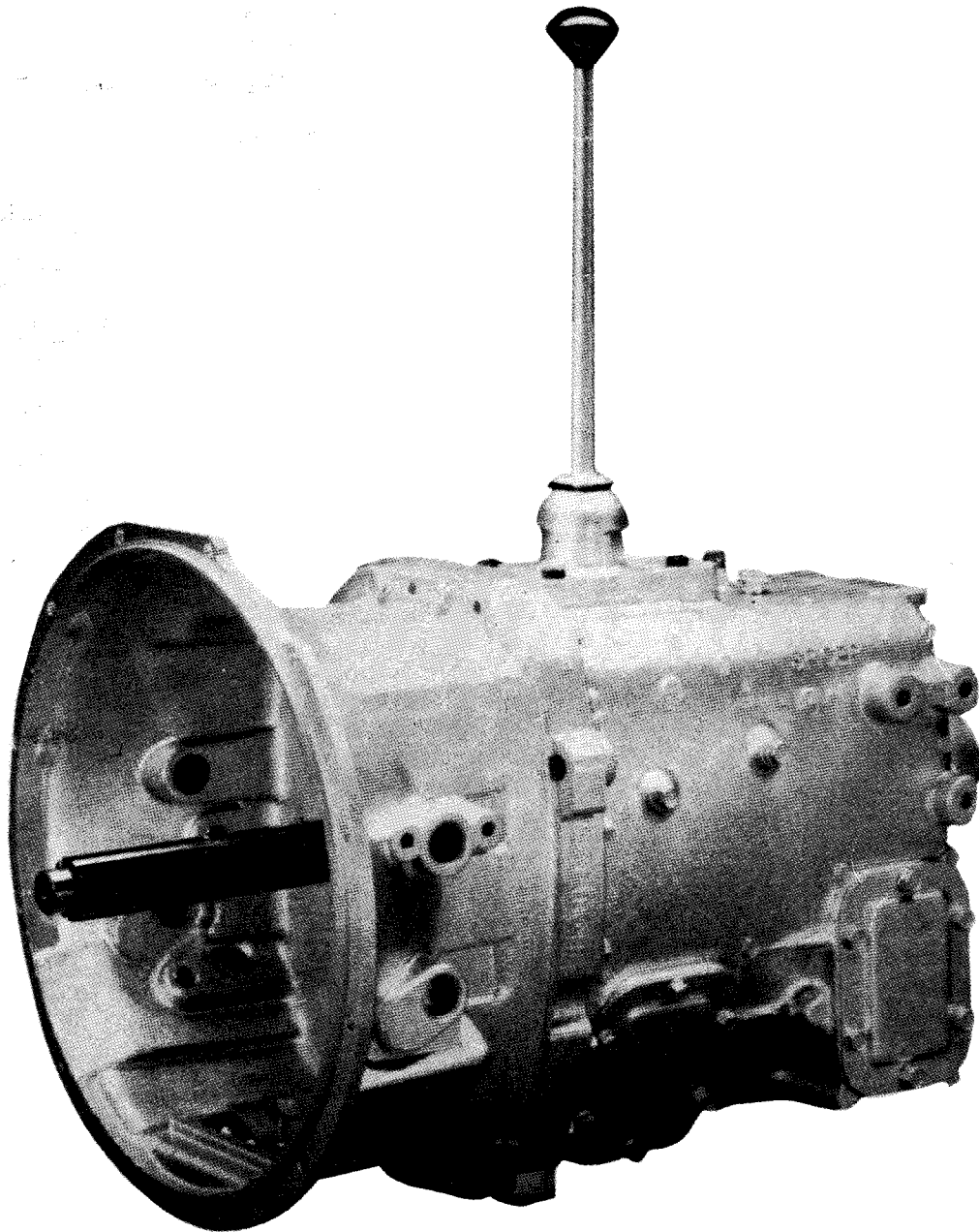

## **CM49 Series Transmission**



**CONTENTS**

**RATIO TABLE** ..... 1

**GEARS and RELATED PARTS** ..... 2-5

**DRIVE GEAR GROUP** ..... 2-3

**MAINSHAFT GROUP** ..... 2-3

**COUNTERSHAFT GROUP** ..... 4-5

**REVERSE IDLER SHAFT GROUP** ..... 4-5

**DRIVE GEAR TABLE** ..... 5

**DRIVE GEAR BEARING CAP CHART WITH CLUTCH APPLICATIONS** ..... 6

**CLUTCH HOUSING & DRIVE GEAR BEARING CAP GROUP** ..... 6-7

**CLUTCH HOUSING DIMENSIONS** ..... 7

**CASE GROUP** ..... 8-9

**CASE TABLE** ..... 9

**REAR BEARING CAP CHART WITH BRAKE APPLICATIONS** ..... 10

**REAR BEARING CAP GROUP and RELATED PARTS** ..... 10-11

**REMOTE CONTROL ASSEMBLY** ..... 12

**END YOKES** ..... 13

**SHIFT BAR and FORK ASSEMBLY** ..... 14

**SHIFT LEVER and DOME ASSEMBLY** ..... 15

**CLUTCH RELEASE PARTS and DIMENSIONS** ..... 16-17

**OVERHAUL KITS—MAJOR and MINOR** ..... 18-19

**TABULATED BILLS OF MATERIALS** ..... 20-21

**RATIO TABLE**

| SPEEDS | MODELS |        |
|--------|--------|--------|
|        | 4954-A | 4954-D |
| 1st    | 7.25   | 7.25   |
| 2nd    | 3.98   | 3.98   |
| 3rd    | 2.23   | 2.23   |
| 4th    | 1.44   | 1.29   |
| 5th    | 1.00   | 1.00   |
| Rev.   | 7.25   | 7.25   |

Parts listed in this catalog may no longer be available. Use with transmission superseding list.

**IDENTIFICATION**

The Name Plate (NP-96) affixed to the RIGHT side of the Transmission is stamped with information:

Abbreviations used in this parts list include:  
 N.S. — Not Shown  
 N.S.S. — Not Sold Separately  
 N.R. — Not Required

SERIAL

B/M No.  MODEL

In requesting more information on these transmissions, furnish the B/M No. and the Serial Number.

# MODEL CM49

SPICER®



T210-CM49

GEARS and RELATED PARTS

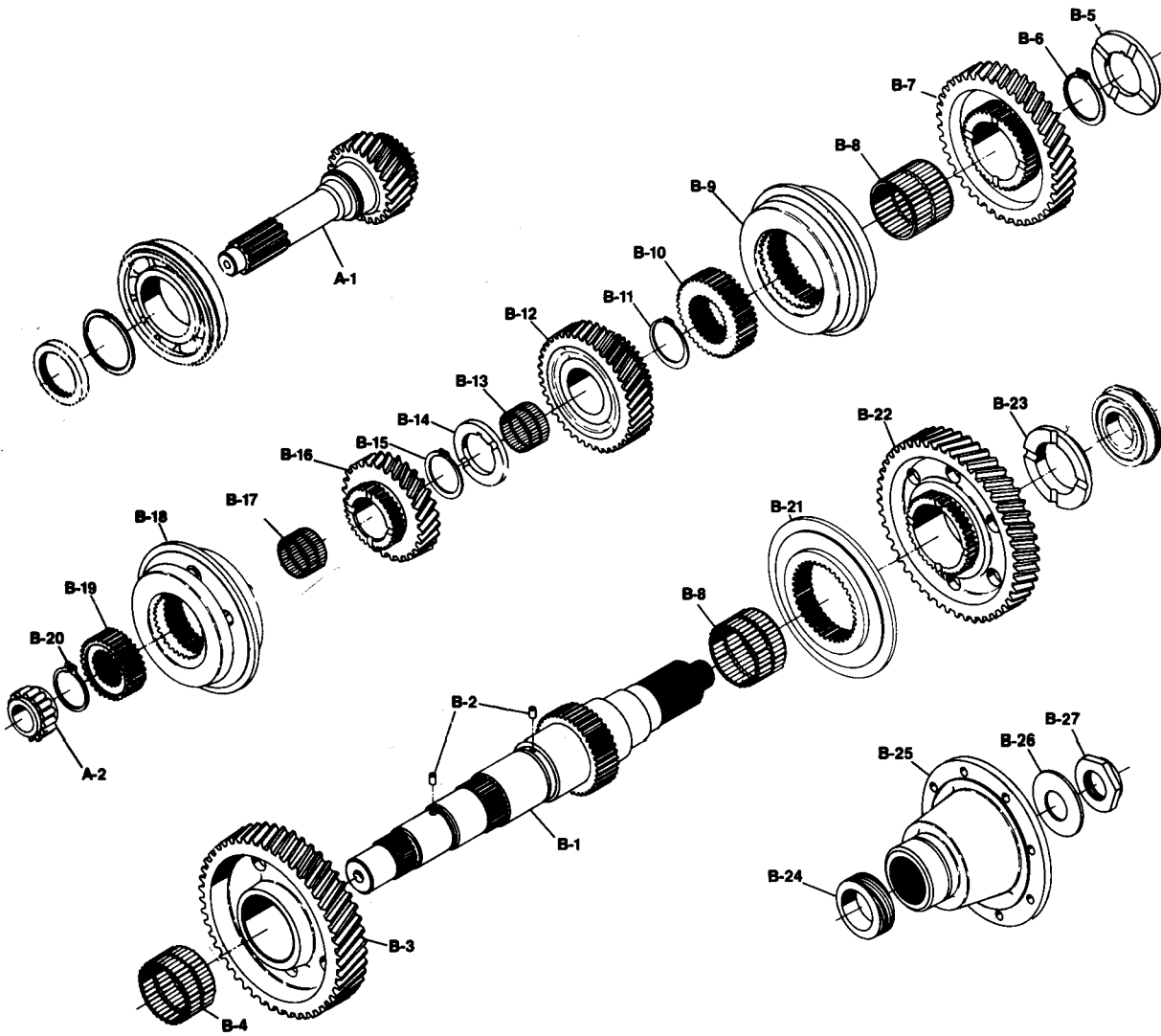



| Ref. No. | Part Number   | Part Description  | Qty.        |
|----------|---------------|---|-------------|
| A-1      | See Tab Bills | <b>DRIVE GEAR GROUP—INPUT</b>   |             |
| A-2      | 550986        | Gear—drive—input (see table page 5).....  | 1           |
|          |               | Bearing—mainshaft pocket.....   | 1           |
|          |               | <b>MAINSHAFT GROUP—OUTPUT</b>   |             |
| B-1      | 49-362-1      | Mainshaft.....  | 1           |
| B-2      | 545087        | Pin—thrust washer lock.....   | 2           |
| B-3      | 49-8-3        | Gear—1st speed (45T) mainshaft.....   | 1           |
| B-4      | 550991        | Bearing—1st & reverse gear needle.....  | 1           |
| B-5      | 49-47-1       | Thrust Washer—1st & 2nd speed gear.....   | 1           |
| B-6      | 49-381-1      | Snap Ring—1st & 2nd thrust washer.....  | 1           |
| B-7      | 49-8-5        | Gear—2nd speed (38T), mainshaft.....  | 1           |
| B-8      | 550963        | Bearing—2nd & reverse speed needle.....   | 2           |
| B-9      | 313547X       | (BEFORE SERIAL NO. J870128008 SERVICE WITH 313614—2X)<br>Synchronizer—2nd & 3rd (see page 14).....  | 1           |
| B-9      | 313616X       | (AFTER SERIAL NO. J870128008)<br>Synchronizer—2nd & 3rd speed.....  | 1           |
| B-10     | 49-466-1      | Gear—2nd & 3rd speed clutch.....  | 1           |
| B-11     | 40-381-4      | Snap Ring—2nd & 3rd clutch gear.....  | 1           |
| B-12     | 49-8-7        | Gear—3rd speed (34T), mainshaft.....  | 1           |
| B-13     | 550968        | Bearing—3rd speed mainshaft needle.....   | 1           |
| B-14     | 49-47-2       | Thrust Washer—3rd & 4th speed gear.....   | 1           |
| B-15     | 40-381-3      | Snap Ring—3rd & 4th thrust washer.....  | 1           |
| B-16     | 49-8-9        | Gear—4th speed, mainshaft.....  | 1           |
|          | 49-8-11       | (22T) for 4954-A<br>(21T) for 4954-D  |             |
| B-17     | 550990        | Bearing—4th speed mainshaft gear.....   | 1           |
| B-18     | 313558X       | Synchronizer—4th & 5th speed gear.....  | 1           |
| B-19     | 49-466-2      | Gear—4th & 5th speed clutch (33T).....  | 1           |
| B-20     | 40-381-1      | Snap Ring—4th & 5th clutch gear.....  | 1           |
| B-21     | 49-465-6      | (BEFORE SERIAL NO. J860919001 SERVICE WITH 313615-2X)<br>Clutch Collar—1st & reverse (See page 14).....                                     | 1           |
| B-21     | 49-465-7      | (AFTER SERIAL NO. J860919001)<br>Clutch Collar—1st & reverse.....   | 1           |
| B-22     | 49-8-1        | Gear—reverse (45T).....   | 1           |
| B-23     | 49-47-8       | Thrust Washer—reverse.....  | 1           |
| B-24     | See Tab Bills | Gear—speedometer drive.....   | 1           |
| B-25     | See Tab Bills | Companion flange or end yoke.....   | 1           |
| B-26     | 53-205-1      | Washer—mainshaft nut.....   | 1           |
| B-27     | 501200        | Nut—mainshaft (1.250-18).....   | 1           |
|          |               | 313723-2X (BSN J910906001)<br>- 101-465-7 collar .125/.125<br>313723-1X<br>313723X FORK & BAR<br>101-486-1 CLIP<br>101-438-4 PUPPET PLUNGER | 1<br>2<br>1 |

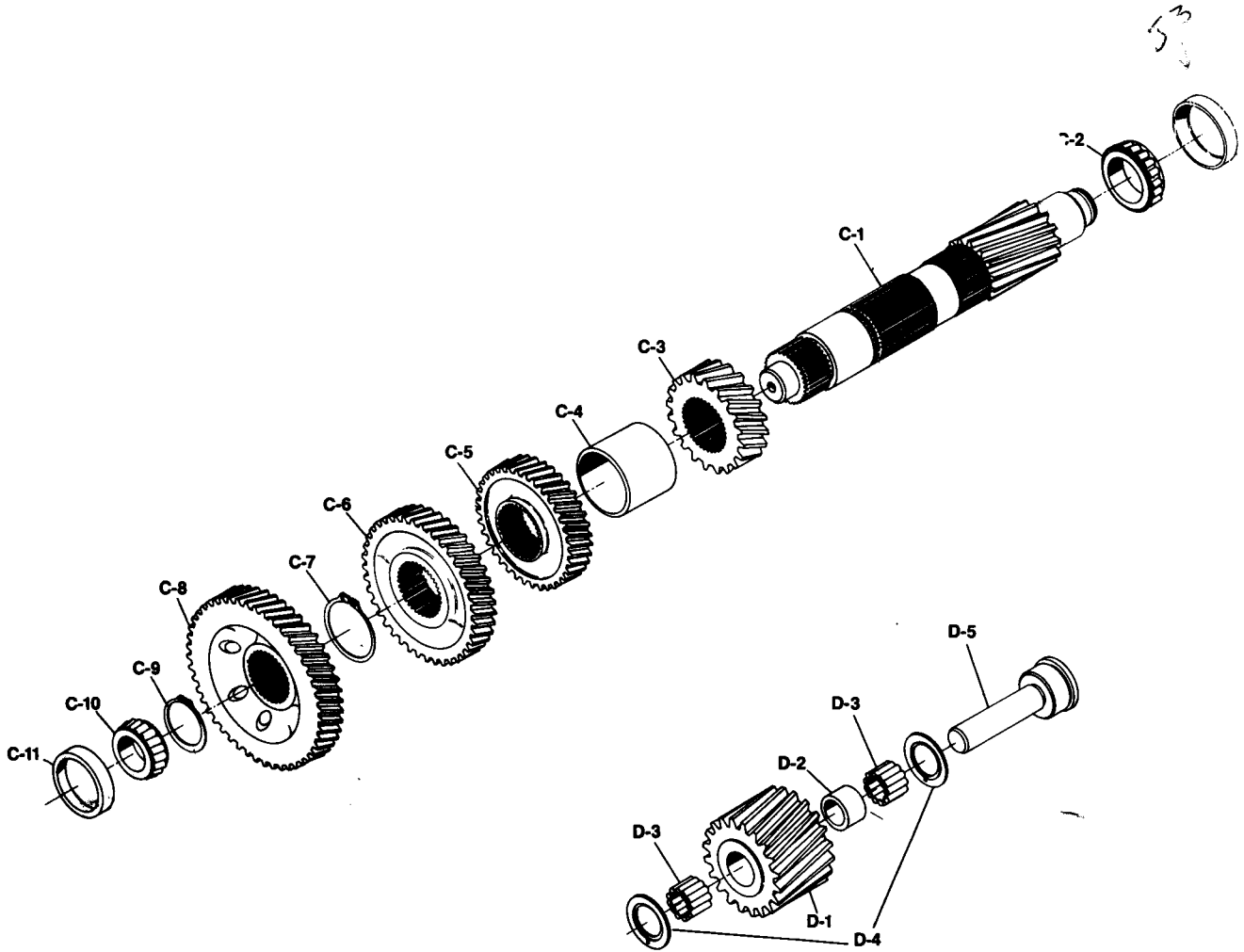



| Ref. No.                         | Part Number | Part Description  | Qty. |
|----------------------------------|-------------|---|------|
| <b>COUNTERSHAFT GROUP</b>        |             |   |      |
| C-1                              | 49-30-3     | Countershaft (with P.T.O drive) <i>WOW 49-30-1 w/o P.T.O.</i> | 1    |
| C-2                              | 550868      | Cone—bearing—countershaft rear                                | 1    |
| C-3                              | 49-196-1    | Gear—2nd speed (20T), countershaft                            | 1    |
| C-4                              | 49-37-5     | Spacer—2nd & 3rd speed gear                                   | 1    |
| C-5                              | 49-196-3    | Gear—3rd speed (32T), countershaft                            | 1    |
| C-6                              |             | Gear—4th speed, countershaft                                  | 1    |
|                                  | 49-196-5    | (32T) for 4954-A  |      |
|                                  | 49-196-7    | (34T) for 4954-D  |      |
| C-7                              | 27-381-5    | Snap Ring—4th countershaft gear                               | 1    |
| C-8                              | 49-1-1      | Gear—drive (44T), countershaft                                | 1    |
| C-9                              | 40-381-3    | Snap Ring—countershaft drive gear                             | 1    |
| C-10                             | 550964      | Cone—bearing—countershaft front                               | 1    |
| C-11                             | 550965      | Cup—bearing—countershaft front                                | 1    |
| <b>REVERSE IDLER SHAFT GROUP</b> |             |   |      |
| D-1                              | 49-5-1      | Gear—reverse idler (19T)                                      | 1    |
| D-2                              | 97-37-1     | Spacer—bearing reverse idler gear                             | 1    |
| D-3                              | 550886      | Bearing—reverse idler   | 2    |
| D-4                              | 974-W       | Thrust Washer—reverse idler                                   | 2    |
| D-5                              | 40-60-1     | Shaft—idler gear  | 1    |

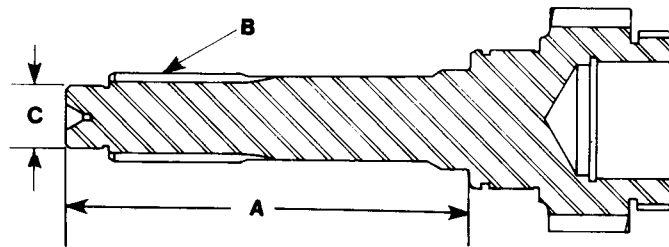

**DRIVE GEAR TABLE**

| A Overall Length        | B Spline Dia. Teeth | C-Pilot Size | Drive Gear Assembly (Includes 49-468-2) |
|-------------------------|---------------------|--------------|---|
| 21 Teeth for Model CM49 |                     |              |   |
| 9.929"                  | 1½" -10             | .9837"       | 49-35-3-1X                              |
| 8.179"                  | 1½" -10             | .9837"       | 49-35-4-1X                              |
| 9.875"                  | 1¾" -10             | 1.1800"      | 49-35-6-1X                              |
| 9.929"                  | 1¾" -10             | .9837"       | 49-35-8-1X                              |

# MODEL CM49

**SPICER®**

**T210-CM49 CLUTCH HOUSING and DRIVE GEAR BEARING CAP GROUP**

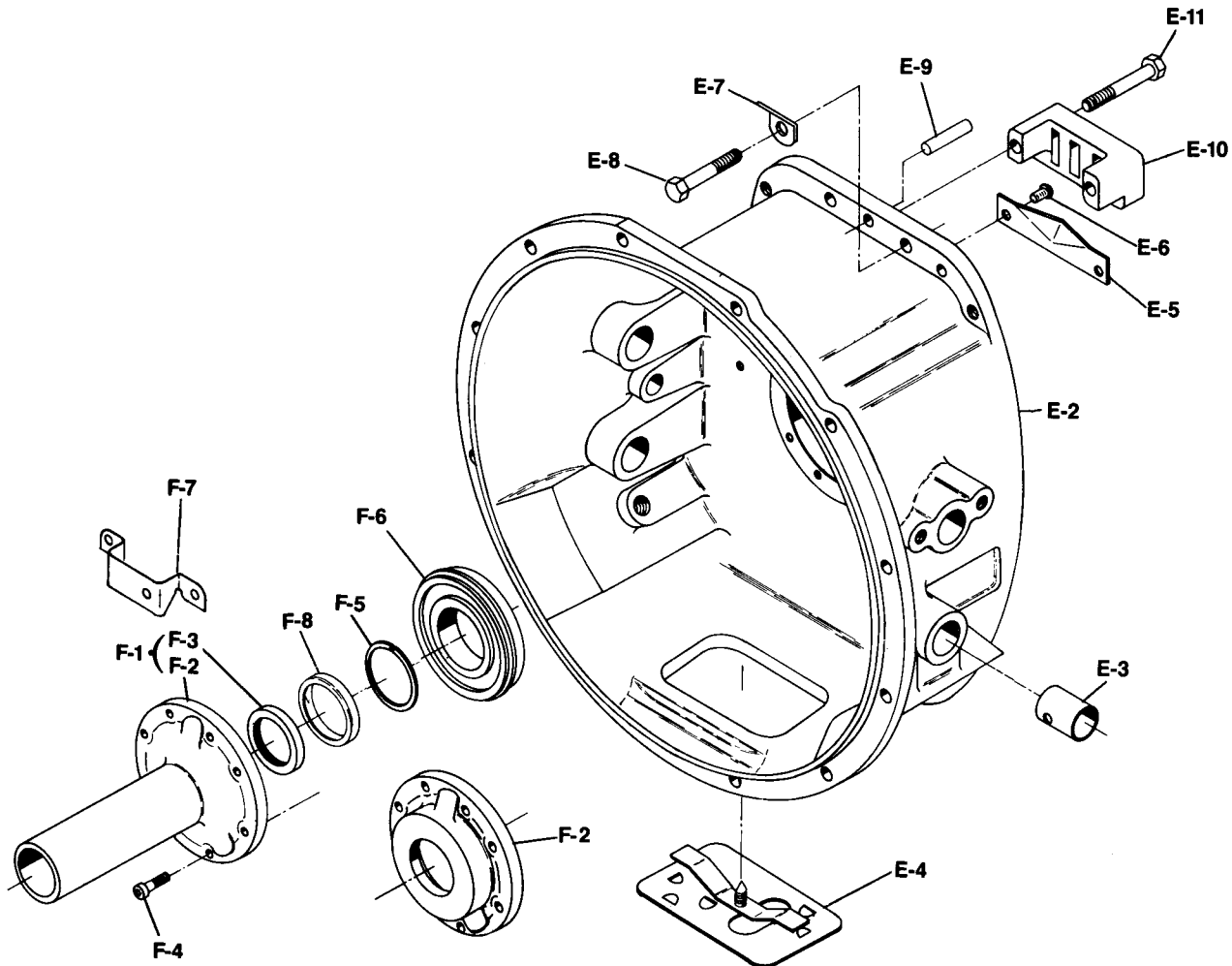

**DRIVE GEAR BEARING CAP CHART**

| A<br>Outside<br>Diameter   | B<br>Stem<br>Diameter             | C<br>Length                       | D<br>Inside Diameter<br>For Oil Seal | FRONT BEARING CAP F-1     |                                |
|--|-----------------------------------|-----------------------------------|--------------------------------------|---------------------------|--------------------------------|
|  |                                   |                                   |                                      | Part Number<br>N.S.S. F-2 | Assy. Includes<br>Oil Seal F-3 |
| <b>FLAT TYPE—For Spicer Pull Type Clutches . . . . . PULL TYPE RELEASE</b> |                                   |                                   |                                      |                           |                                |
| 5 <sup>5</sup> / <sub>16</sub> "   | —                                 | 1 <sup>7</sup> / <sub>16</sub> "  | 2 <sup>9</sup> / <sub>16</sub> "     | 40-19-40                  | 40-19-40-1X                    |
| <b>STEM TYPE—For all Push Type Clutches . . . . . PUSH TYPE RELEASE</b>    |                                   |                                   |                                      |                           |                                |
| 5 <sup>5</sup> / <sub>16</sub> "   | 1 <sup>15</sup> / <sub>16</sub> " | 6 <sup>17</sup> / <sub>64</sub> " | 2 <sup>1</sup> / <sub>16</sub> "     | 40-19-1                   | 40-19-1-1X                     |
| 5 <sup>5</sup> / <sub>16</sub> "   | 1 <sup>7</sup> / <sub>8</sub> "   | 6 <sup>21</sup> / <sub>32</sub> " | 2 <sup>1</sup> / <sub>16</sub> "     | 40-19-24                  | 40-19-24-1X                    |
| 5 <sup>5</sup> / <sub>16</sub> "   | 1 <sup>7</sup> / <sub>8</sub> "   | 4 <sup>59</sup> / <sub>64</sub> " | 2 <sup>1</sup> / <sub>16</sub> "     | 40-19-32 NLA              | 40-19-32-1X                    |
| 5 <sup>5</sup> / <sub>16</sub> "   | 1 <sup>7</sup> / <sub>8</sub> "   | 6 <sup>21</sup> / <sub>32</sub> " | 2 <sup>1</sup> / <sub>16</sub> "     | 40-19-35                  | 40-19-35-1X                    |

N.S.S.—Not Sold Separately

PARTS LISTED IN THIS CATALOG MAY NO LONGER BE AVAILABLE, USE WITH TRANSMISSION SUPERSEDING LIST.



| Ref. No.                            | Part Number   | Part Description                                 | Qty. |
|-------------------------------------|---------------|--|------|
| <b>CLUTCH HOUSING</b>               |               |  |      |
| E-2                                 | See Tab Bills | Clutch Housing Assembly (see page 20)            | 1    |
|                                     | See Below     | Clutch Housing                                   | 1    |
| E-3                                 | 128C-20       | Bushing—clutch release shaft                     | 2    |
| E-4                                 | 46-96-2-1X    | Hand Hole Cover Assembly                         | 1    |
| E-5                                 | 40-468-1      | Oil Trough                                       | 1    |
| E-6                                 | 545088        | Pin—drive oil trough                             | 2    |
| E-7                                 | 330564-1      | Lift Hook  | 1    |
| E-8                                 | 545082-7      | Bolt—clutch housing to case (MF10 × 1.25 × 55mm) | 16   |
| E-9                                 | 545086-6      | Dowel Pin—case front                             | 2    |
| E-10                                | 49-477-1      | Support—front shift bar                          | 1    |
| E-11                                | 545082-9      | Bolt—shift bar support (MF10 × 1.25 × 35mm)      | 2    |
| N.S.                                | 500169-5      | Nipple—clutch release shaft                      | 2    |
| <b>DRIVE GEAR BEARING CAP GROUP</b> |               |  |      |
| F-1                                 | See Tab Bills | Cap & Seal Assembly (see table page 6)           | 1    |
| F-2                                 | N.S.S.        | Cap  | 1    |
| F-3                                 | 40-463-6-1X   | Seal—drive gear bearing cap (stem only)          | 1    |
| or                                  | 40-463-4-1X   | Seal—drive gear bearing cap (flat only)          | 1    |
| F-4                                 | 545093        | Cap Screw—drive gear bearing cap                 | 8    |
| F-5                                 | 97-381-30     | Snap Ring—bearing drive gear front               | 1    |
| F-6                                 | 550988        | Bearing—drive gear, front                        | 1    |
| F-7                                 | 40-411-1      | Return spring bracket (Navistar only)            | 1    |
| F-8                                 | 49-468-2      | Oil Ring   | 1    |

**CLUTCH HOUSING DIMENSIONS**

| SAE      |                                  |                                  |
|----------|----------------------------------|----------------------------------|
| Size No. | A Pilot Dia.                     | B O.D.                           |
| 1        | 20 <sup>1</sup> / <sub>8</sub> " | 21 <sup>3</sup> / <sub>4</sub> " |
| 2        | 17 <sup>5</sup> / <sub>8</sub> " | 19 <sup>1</sup> / <sub>4</sub> " |
| 3        | 16 <sup>1</sup> / <sub>8</sub> " | 17 <sup>3</sup> / <sub>4</sub> " |

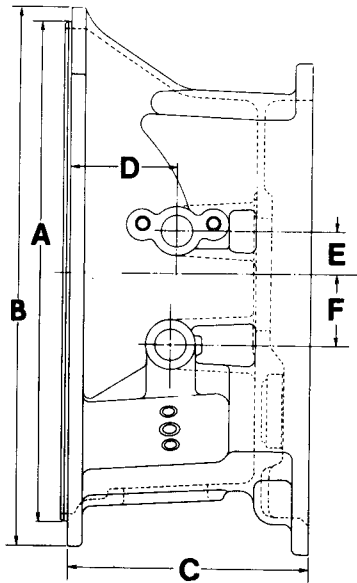

| CLUTCH HOUSING |          |             |       |                                   | RELEASE SHAFT HOLE |  |                                 |                                      |
|----------------|----------|-------------|-------|-----------------------------------|--------------------|--|---------------------------------|--------------------------------------|
| Assembly No.   | Part No. | Casting No. | S A E | C Length                          | Dia.               | D C/L to Front Face  | E Above C/L                     | F Below C/L                          |
| †49-518-4-2X   | 49-518-4 | C40-518-2   | 2     | 8 <sup>17</sup> / <sub>32</sub> " | 1"                 | 3 <sup>3</sup> / <sub>4</sub> "<br>3 <sup>19</sup> / <sub>32</sub> " | 1 <sup>1</sup> / <sub>2</sub> " | —<br>2 <sup>1</sup> / <sub>2</sub> " |
| †49-518-5-2X   | 49-518-5 | C40-518-2-1 | 2     | 8 <sup>17</sup> / <sub>32</sub> " | 1"                 | 3 <sup>3</sup> / <sub>4</sub> "<br>2 <sup>9</sup> / <sub>16</sub> "  | 1 <sup>1</sup> / <sub>2</sub> " | —<br>3"                              |
| 49-518-6-1X    | 49-518-6 | C40-518-4-1 | 2     | 6.802"                            | —                  | —  | —                               | —                                    |

†Includes (4) release shaft bushings 128C-20.



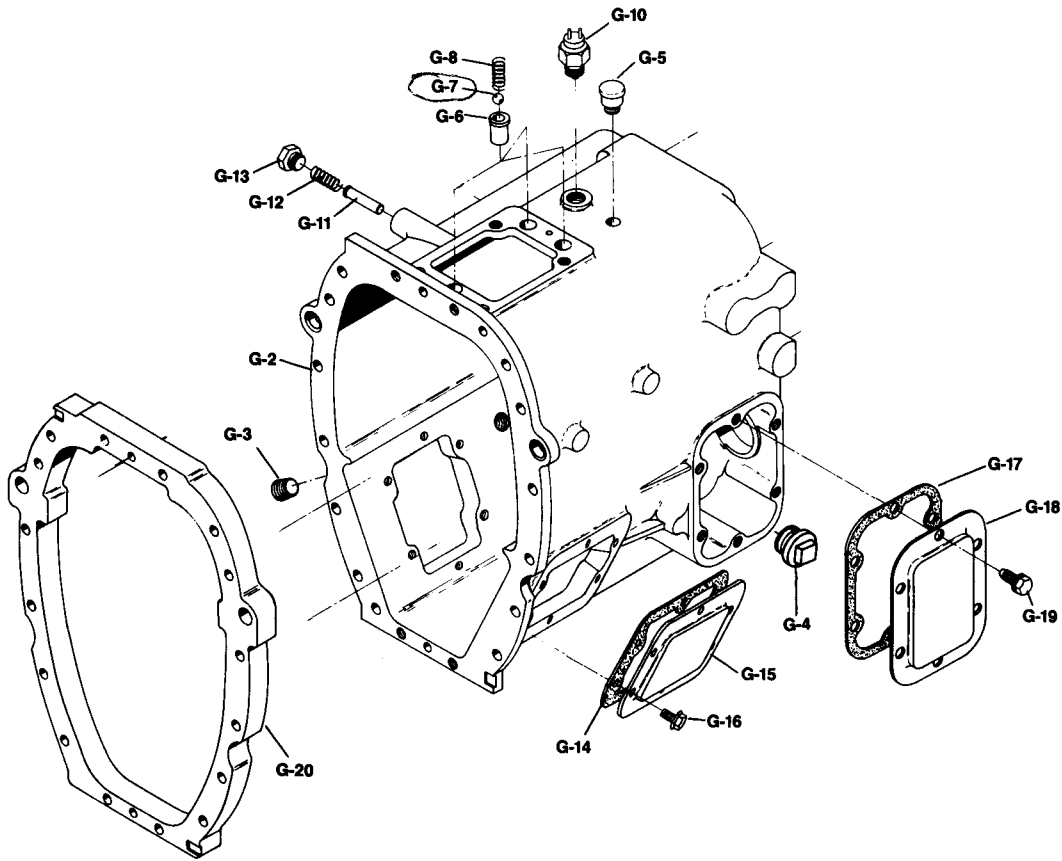



| Ref. No.          | Part Number   | Part Description  | Qty. |
|-------------------|---------------|---|------|
| <b>CASE GROUP</b> |               |   |      |
| G-1               | See Tab Bills | Case Assembly (see case table below)                            | 1    |
| G-2               | N.S.S.        | Case  | 1    |
| N.S.              | NP-96         | Plate—name  | 1    |
| N.S.              | NP-196        | Plate—patent  | 1    |
| N.S.              | 252-SP        | Pin—nameplate   | 4    |
| N.S.              | 330934        | Magnet Cermic   | 1    |
| N.S.              | 330800        | Plug—side hole (3/8" -16 x 3/4")                                | 2    |
| G-3               | 500100        | Plug—filler (3/4" -14 N.P.T.F.)                                 | 1    |
| G-4               | 62-39-3       | Plug—magnetic drain (3/4" -14 N.P.T.F.)                         | 1    |
| G-5               | 312268        | Breather—assembly   | 1    |
| G-6               | 40-487-1      | Insert—poppet spring & ball                                     | 3    |
| G-7               | 40-80-1       | Ball—poppet <i>101-438-4 ASN J880705001</i>                     | 3    |
| G-8               | 97-72-23      | Spring—shift bar poppet   | 3    |
| G-10              | 313538        | Switch—back-up lite (Navistar only)                             | 1    |
| or                | 313539        | Switch—back-up lite (Ford)                                      | 1    |
| G-11              | 40-438-1      | Pin—1st & reverse select plunger                                | 1    |
| G-12              | 62-72-8       | Spring—1st & reverse shift finger plunger                       | 1    |
| or                | 40-72-3       | Spring—1st & reverse shift finger plunger (R.V.I.)              | 1    |
| G-13              | 40-59-1       | Plug—1st & reverse plunger                                      | 1    |
| G-14              | 97-324-1-1X   | Gasket—6 bolt P.T.O. aperture cover                             | 2    |
| G-15              | 50-267-2      | Cover—6 bolt P.T.O. aperture                                    | 2    |
| G-16              | 330800        | Bolt—P.T.O. aperture (3/8" -16 x 3/4")                          | 12   |
| G-17              | 49-324-1-1X   | Gasket—reverse idler cover                                      | 1    |
| G-18              | 40-96-3       | Cover—reverse idler   | 1    |
| G-19              | 545085        | Bolt—reverse idler cover (M10 x 1.5 x 20mm) <i>self tapping</i> | 6    |
| G-20              | 49-215-1      | Spacer—case to clutch housing                                   | 1    |

**CASE TABLE**

| Case Assembly<br>G-2 | Case Casting No.<br>(N.S.S.) | Plug—<br>Side Hole<br>(N.S.) | 4 Pins N.S.<br>(252-SP)<br>Nameplate<br>N.S. | OIL PLUG      |              | G-6<br>Poppet<br>Insert | G-5<br>Breather | Used by  |
|----------------------|------------------------------|------------------------------|--|---------------|--------------|-------------------------|-----------------|----------|
|                      |                              |                              |  | G-3<br>Filler | G-4<br>Drain |                         |                 |          |
| 49-15-1-1X           | C49-15-2                     | —                            | NP-96  | 500100        | 62-39-3      | 40-487-1                | 312268          | Navistar |
| 49-15-4-1X           | C49-15-2                     | 330800                       | NP-96  | 500100        | 62-39-3      | 40-487-1                | 312268          |          |

N.S.—Not Shown

N.S.S.—Not Sold Separately

# MODEL CM49

SPICER®



T210-CM49

## REAR BEARING CAP GROUP and RELATED PARTS

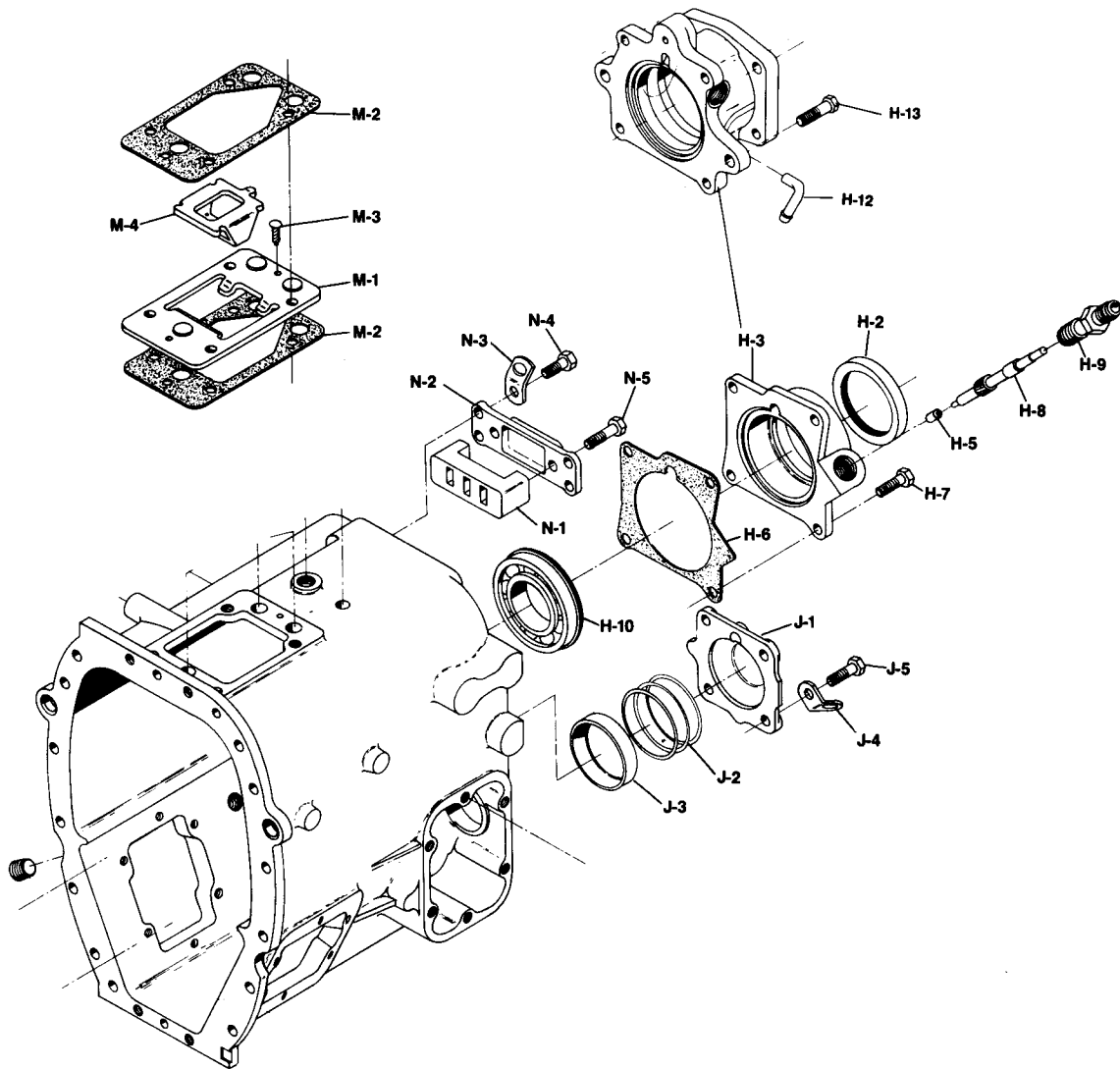

| BEARING CAP ASSEMBLY INCLUDES |          |                           |                     |          |          |
|-------------------------------|----------|---------------------------|---------------------|----------|----------|
| Part Number                   | Oil Seal | Casting Number            | Speedometer Bushing |          |          |
| H-1                           | H-2      | —                         | H-5                 | Brake    | Used By  |
| 40-19-19-2X                   | 63-463-1 | C 40-19- <del>19</del> 20 | 60-475-1            | DCM 12x4 | Navistar |
| 40-19-22-2X                   | 63-463-1 | C 40-19- <del>22</del> 23 | 60-475-1            | DCM 9x3  | Navistar |
| 40-19-38-2X                   | 63-463-1 | 40-19-38                  | 60-475-1            | — AIR    | Navistar |
| 40-19-39-1X                   | 63-463-1 | 40-19-39                  | —                   | —        | Ford     |
| 40-19-41-2X                   | 63-463-1 | 40-19-41                  | —                   | DCM      | Navistar |
| 40-19-42-2X                   | 63-463-1 | 40-19-42                  | —                   | DCM      | Navistar |
| 40-19-43-2X                   | 63-463-1 | 40-19-43                  | 60-475-1            | —        | Navistar |

PARTS LISTED IN THIS CATALOG MAY NO LONGER BE AVAILABLE, USE WITH TRANSMISSION SUPERSEDING LIST.

*w electronic or mech. speeds*



| Ref. No.                                   | Part Number        | Part Description                                     | Qty. |
|--|--------------------|--|------|
| <b>MAINSHAFT REAR BEARING CAP GROUP</b>    |                    |  |      |
| H-1  | See Tab Bills      | Cap Assembly—mainshaft bearing cap (see page 10)     | 1    |
| H-2  | 63-463-1           | Oil Seal—mainshaft rear bearing cap                  | 1    |
| H-3  | See page 10        | Cap Sub Assembly—mainshaft rear                      | 1    |
| H-4  | N.S.S.             | Cap—mainshaft rear bearing                           | 1    |
| H-5  | See Page 10        | Bushing—speedometer                                  | 1    |
| H-6  | 40-223-1 -4 WSE    | Gasket—mainshaft rear bearing cap                    | 1    |
| or   | 40-223-3 -5 "      | Gasket—mainshaft rear bearing cap (brake only)       | 1    |
| H-7  | 545082-3           | Bolt—rear bearing cap (MF10 x 1.378 x 35mm)          | 4    |
| H-8  | See Tab Bills      | Gear—speedometer drive                               | 1    |
| H-9  | 55-454-1           | Sleeve—1¼" speedometer driven gear                   | 1    |
| or   | 97-454-2-1X        | Sleeve & oil seal                                    | 1    |
| N.S.                                       | 44-539-1           | Cap—speedometer dust                                 | 1    |
| N.S.                                       | 55-334-1           | Plug—speedometer (used without driven gear)          | 1    |
| N.S.                                       | 545106             | Plug—speedometer outlet (electronic)                 | 1    |
| H-10                                       | 550989             | Bearing—mainshaft rear                               | 1    |
| H-11                                       | 545021             | Plug—electronic speedometer (Ford)                   | 1    |
| H-12                                       | 37179              | Tube—vent (assembly to front of transmission)        | 1    |
| H-13                                       | 545084-2           | Bolt—cap (D.C.M. Brake) (MF12 x 1.25 x 35mm)         | 2    |
| or   | 545084-4           | Plug—case (rear holes) (MF12 x 1.25 x 16mm)          | 2    |
| <b>COUNTERSHAFT REAR BEARING CAP GROUP</b> |                    |  |      |
| J-1  | 49-22-1            | Cap—countershaft rear bearing                        | 1    |
| J-2  | 49-228-1-1         | Shim—countershaft rear bearing (.0055/.0045)         | 1    |
|  | 49-228-1-2         | (.0110/.0090)  | 1    |
|  | 49-228-1-3         | (.0165/.0135)  | 1    |
| J-3  | 550978             | Cup—countershaft rear bearing                        | 1    |
| J-4  | 330564-1           | Lift hook  | 1    |
| J-5  | 545002-4           | Bolt—countershaft rear bearing cap (.375-16 x 1.750) | 4    |
| <b>INTERLOCK GROUP</b>                     |                    |  |      |
| M-1  | 40-200-1           | Plate—interlock retainer                             | 1    |
| M-2  | 40-155-1 101-118-1 | Gasket—case to interlock plate                       | 2    |
| M-3  | 545091             | Screw—drive (interlock retainer)                     | 2    |
| M-4  | 40-200-2           | Plate—interlock                                      | 1    |
| <b>REAR SHAFT BAR SUPPORT GROUP</b>        |                    |  |      |
| N-1  | 40-477-2           | Support—rear shift bar                               | 1    |
| N-2  | 40-96-1            | Cap—rear shift bar                                   | 1    |
| N-3  | 330564-1           | Lift hook  | 1    |
| N-4  | 545082-1           | Bolt—bar cap (MF10 x 1.25 x 25mm)                    | 4    |
| N-5  | 545082-3           | Bolt—bar support (MF10 x 1.25 x 35mm)                | 2    |

N.S.S.—Not Sold Separately

# MODEL CM49

SPICER®



T210-CM49

## REMOTE CONTROL ASSEMBLY

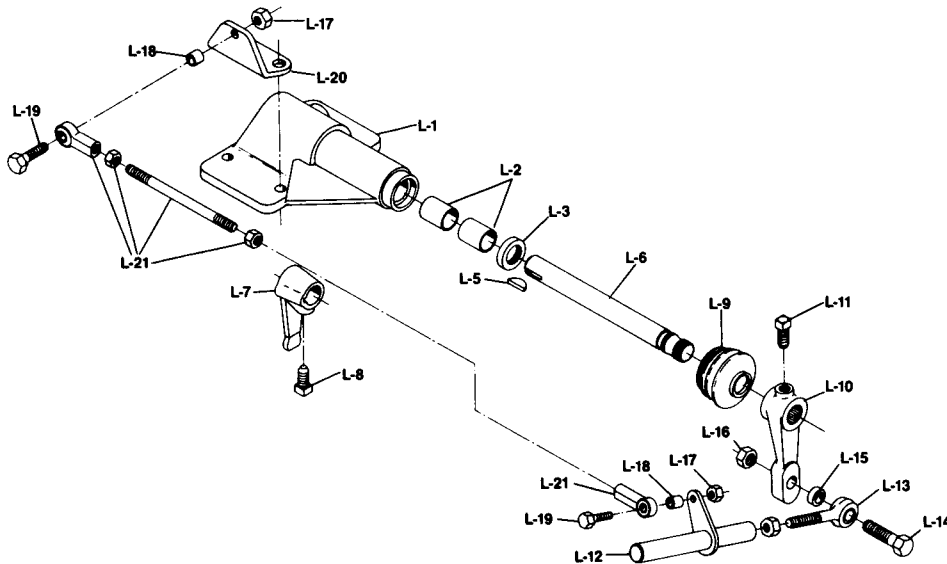

| Ref. No. | Part Number          | Part Description   | 40-18-1-2X | 40-18-1-3X | 40-18-1-6X |
|----------|----------------------|--|------------|------------|------------|
|          | <b>See Tab Bills</b> | Remote control assembly . . . . .  | 1          | 1          | 1          |
|          | <b>40-18-1-1X</b>    | Remote control cover assembly . . . . .                                  | 1          | 1          | 1          |
| L-1      | <b>N.S.S.</b>        | Remote control cover . . . . .   | 1          | 1          | 1          |
| L-2      | <b>40-24-1</b>       | Bushing—remote control cover . . . . .                                   | 2          | 2          | 2          |
| L-3      | <b>28P-19</b>        | Seal—remote control rod . . . . .  | 1          | 1          | 1          |
| L-4      | <b>40-65-1-1X</b>    | Inner shifter shaft, finger and key . . . . .                            | 1          | 1          | 1          |
| L-5      | <b>500007-19</b>     | Key—shift bracket . . . . .  | 1          | 1          | 1          |
| L-6      | <b>40-65-1</b>       | Shaft—remote control . . . . .   | 1          | 1          | 1          |
| L-7      | <b>40-6-1</b>        | Finger—shift . . . . .   | 1          | 1          | 1          |
| L-8      | <b>545004-1</b>      | Set screw— $\frac{7}{16}$ "-20 x 72" square head . . .                   | 1          | 1          | 1          |
| L-9      | <b>97-483-3</b>      | Boot—shift rod . . . . .   | 1          | 1          | 1          |
| N.S      | <b>LW-3-9</b>        | Lockwire . . . . .   | 1          | 1          | 1          |
| L-10     | <b>40-6-3</b>        | Control lever . . . . .  | 1          | —          | 1          |
| or       | <b>40-6-5</b>        | Control lever . . . . .  | —          | 1          | —          |
| L-11     | <b>500550-7</b>      | Set screw— $\frac{7}{16}$ "-14 x $\frac{7}{8}$ " square head . . . . .   | 1          | 1          | 1          |
| L-12     | <b>40-65-3-1X</b>    | Shift rod . . . . .  | 1          | 1          | —          |
| L-13     | <b>330938</b>        | Rod end . . . . .  | 1          | 1          | —          |
| L-14     | <b>545001-2</b>      | Bolt—control lever ( $\frac{1}{2}$ "-13 x $2\frac{1}{4}$ " hex head) . . | 1          | 1          | —          |
| L-15     | <b>40-38-2</b>       | Spacer—control lever bolt . . . . .                                      | 1          | 1          | —          |
| L-16     | <b>500370-5</b>      | Nut—control lever and rod end ( $\frac{1}{2}$ "-13 hex) . .              | 1          | 1          | —          |
| L-17     | <b>500370-3</b>      | Nut—tie rod assy. mounting bolt ( $\frac{3}{8}$ "-16 hex) .              | 2          | 2          | —          |
| L-18     | <b>40-38-3</b>       | Spacer—tie rod assembly mounting bolt . . . .                            | 2          | 2          | —          |
| L-19     | <b>545002-7</b>      | Bolt—tie rod assy. ( $\frac{3}{8}$ "-16 x $1\frac{1}{2}$ " hex head) . . | 2          | 2          | —          |
| L-20     | <b>40-354-3</b>      | Bracket—tie rod . . . . .  | 1          | 1          | —          |
| L-21     | <b>40-65-2-1X</b>    | Tie rod assembly . . . . .   | 1          | 1          | —          |

N.S.S.—Not Sold Separately

PARTS LISTED IN THIS CATALOG MAY NO LONGER BE AVAILABLE, USE WITH TRANSMISSION SUPERSEDING LIST.

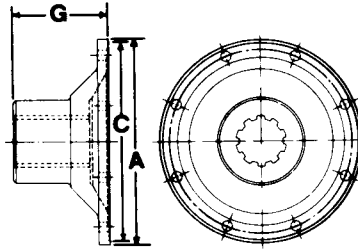

**COMPANION FLANGE**

**Companion Flanges**

| Joint Series | A<br>Flange<br>Diameter | Part No.<br>Companion<br>Flange<br>Assembly | Part No.<br>Companion<br>Flange | G<br>End of Hub<br>to Flange<br>Face Length | C<br>Pilot Diameter<br>F-Female<br>M-Male | Brake<br>Size   |
|--------------|-------------------------|---|---------------------------------|---|---|-----------------|
| 1480/1550    | Rectangular             | —   | 53-106-2                        | 2 <sup>7</sup> / <sub>8</sub> "             | F-3 <sup>3</sup> / <sub>4</sub> "         | 9 x 3 or 12 x 4 |

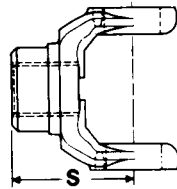

**FULL ROUND**

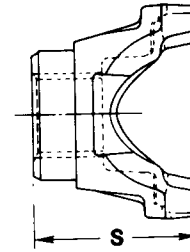

**U-BOLT—BRG. STRAP—HALF ROUND**

| Series | Yoke Style   | End Yoke<br>Part Number | S<br>End of Hub To<br>Center Line Length | Joint Angle                      | Brake Size |
|--------|--------------|-------------------------|--|----------------------------------|------------|
| 1480   | U-Bolt       | 3-4-8781                | 4 <sup>11</sup> / <sub>64</sub> "        | 22 <sup>1</sup> / <sub>2</sub> ° | —          |
| 1480   | Brg. Strap** | 3-4-8931-2              | 3 <sup>29</sup> / <sub>32</sub> "        | 23 <sup>1</sup> / <sub>2</sub> ° | —          |
| 1550   | U-Bolt       | 4-4-4491                | 4 <sup>1</sup> / <sub>64</sub> "         | 21 <sup>1</sup> / <sub>2</sub> ° | —          |
| 1550   | Brg. Strap*  | 4-4-4491-1              | 4 <sup>1</sup> / <sub>64</sub> "         | 21 <sup>1</sup> / <sub>2</sub> ° | —          |
| 1550   | Brg. Strap** | 4-4-4491-2              | 4 <sup>1</sup> / <sub>64</sub> "         | 21 <sup>1</sup> / <sub>2</sub> ° | —          |
| 1550   | U-Bolt       | 4-4-4601                | 6 <sup>27</sup> / <sub>64</sub> "        | 22°                              | 12 x 4     |
| 1550   | U-Bolt       | 4-4-4611                | 4 <sup>11</sup> / <sub>64</sub> "        | 22 <sup>1</sup> / <sub>2</sub> ° | —          |
| 1550   | Brg. Strap*  | 4-4-4611-1              | 4 <sup>11</sup> / <sub>64</sub> "        | 22 <sup>1</sup> / <sub>2</sub> ° | —          |
| 1550   | Brg. Strap** | 4-4-4611-2              | 4 <sup>11</sup> / <sub>64</sub> "        | 22 <sup>1</sup> / <sub>2</sub> ° | —          |
| 1550   | Half Rnd.    | (A) 4-4-6111-1X         | 7 <sup>1</sup> / <sub>32</sub> "         | 22°                              | 12 x 4     |
| 1610   | Full Rnd.    | 5-4-6321                | 4"                                       | 19°                              | —          |
| 1610   | Half Rnd.    | 5-4-6321-1              | 4"                                       | 19°                              | —          |
| 1610   | Full Rnd.    | 5-4-6481                | 4 <sup>11</sup> / <sub>64</sub> "        | 22 <sup>1</sup> / <sub>2</sub> ° | —          |
| 1610   | Half Rnd.    | 5-4-6481-1              | 4 <sup>11</sup> / <sub>64</sub> "        | 22 <sup>1</sup> / <sub>2</sub> ° | —          |
| 1610   | Full Rnd.    | 5-4-6491                | 6 <sup>2</sup> / <sub>32</sub> "         | 22°                              | 12 x 4     |
| 1610   | Half Rnd.    | (A) 5-4-7611-1X         | 7 <sup>9</sup> / <sub>16</sub> "         | 22°                              | 12 x 4     |
| 1710   | Full Rnd.    | 6-4-7301                | 5 <sup>1</sup> / <sub>4</sub> "          | 33 <sup>1</sup> / <sub>2</sub> ° | —          |
| 1710   | Half Rnd.    | 6-4-7301-1              | 5 <sup>1</sup> / <sub>4</sub> "          | 33 <sup>1</sup> / <sub>2</sub> ° | —          |

(A) Assembly Includes Brake Drum

\*With Tapped Holes

\*\*With Thru Holes

# MODEL CM49 SHIFT BAR and FORK ASSEMBLY



*all fork & bar assemblies will be serviced with the deep notch type from the ES52-5. These new parts include the poppet plunger 101-438-4*

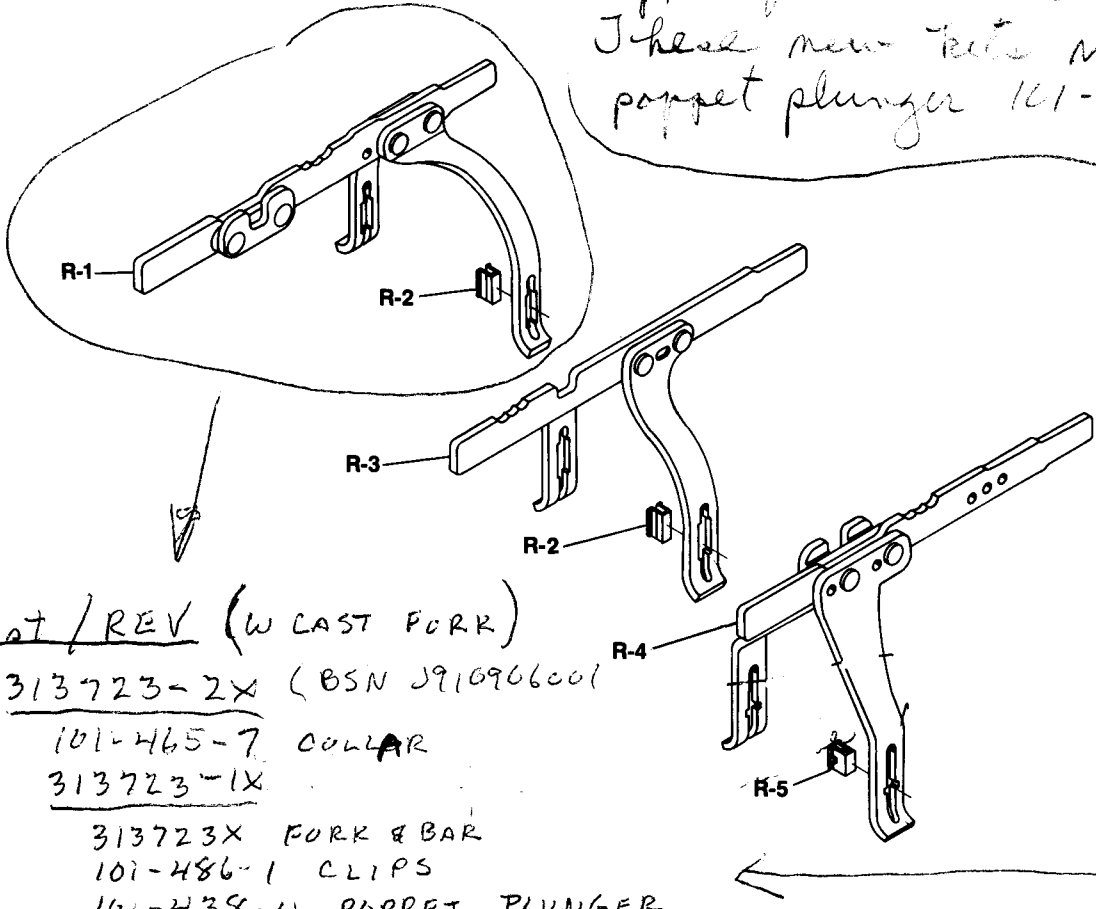

*1st / REV (w CAST FORK)  
313723-2X (BSN J910906001)  
101-465-7 COLLAR  
313723-1X  
313723X FORK & BAR  
101-486-1 CLIPS  
101-438-4 POPPET PLUNGER*

| Ref. No. | Part Number | Part Description   | Qty. | Service With                         |
|----------|-------------|--|------|--------------------------------------|
|          |             | <b>SHIFT BAR and FORK ASSEMBLY<br/>(BEFORE SERIAL NO. J860919001)</b>          |      |                                      |
| R-1      | 313548X -   | Shift Fork and Bar—1st & reverse, clips & collar . . . . .                     | 1    | <del>313615-2X - S/S 313685-2X</del> |
| R-1      | 313615X     | Shift Fork and Bar—1st & reverse, clips . . . . .<br>(PART NO. STAMPED ON TAB) | 1    | <del>313615-3X - S/S 313685-1X</del> |
| R1       | 313723-1X   | <del>ASB J910906001</del><br>(BEFORE SERIAL NO. J860919001)                    |      |                                      |
| R-2      | 49-486-2    | Clip—1st & reverse, 2nd & 3rd shift fork . . . . .                             | 4    | 49-486-2                             |
| R-2      | 49-486-3    | Clip—1st & reverse, 2nd & 3rd shift fork . . . . .                             | 4    | 49-486-3                             |
| R3       | 101-486-1   | <del>ASB J910906001</del><br>(BEFORE SERIAL NO. J87012008)                     |      |                                      |
| R-3      | 313549-1X   | Shift Fork and Bar—2nd & 3rd, clips & synchronizer . . . . .                   | 1    | 313614-2X                            |
| R-3      | 313614X     | Shift Fork and Bar—2nd & 3rd & clips . . . . .                                 | 1    | 313614-1X                            |
| R-4      | 313550X     | Shift Fork and Bar—4th & 5th & clips . . . . .                                 | 1    | 313550-1X                            |
| R-5      | 40-486-1    | Clip—4th & 5th shift fork . . . . .  | 2    | 40-486-1                             |

*313760-2X  
S/S 313688-2X  
S/S 313688-1X  
S/S 313689-1X  
55-313761-1X*



# MODEL CM49

## SHIFT LEVER and DOME ASSEMBLY

T210-CM49

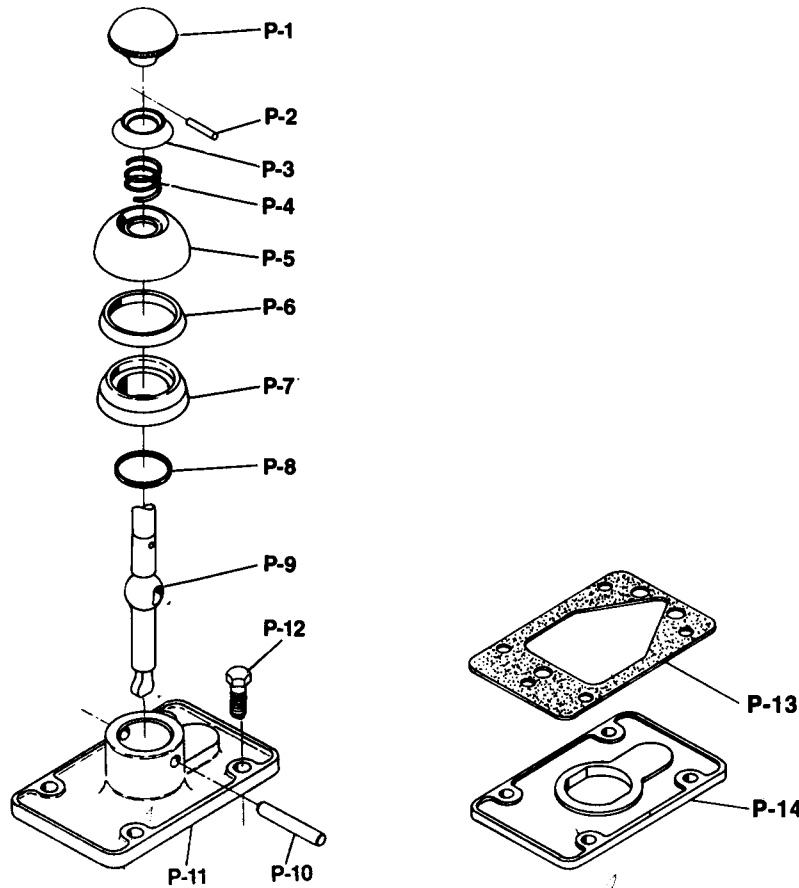

-40x 1686422091

-21x 1648651091

-9x  
-7x  
-6x

also -31x

| Ref. No. | Part Number                | Part Description   | 40-17-1-30X | 40-17-1-12X | 40-17-3-2X | 40-17-3-5X |
|----------|----------------------------|--|-------------|-------------|------------|------------|
|          | <b>See Tab Bills</b>       | Shift lever and dome assembly ...                                      | 1           | 1           | 1          | 1          |
| P-1      | <b>39Q-27</b>              | Handle—shift lever .....   | —           | 1           | 1          | 1          |
| P-2      | <b>286-SP</b>              | Pin—shift lever collar .....   | 1           | 1           | 1          | 1          |
| P-3      | <b>55Q-7</b>               | Collar—compression .....   | 1           | 1           | 1          | 1          |
| P-4      | <b>56Q-25</b>              | Spring—compression .....   | 1           | 1           | 1          | 1          |
| N.S.     | <b>55Q-5</b>               | GROMMET, RUBBER  |             |             |            |            |
| P-5      | <b>54Q-13</b>              | Cup—compression .....  | 1           | 1           | 1          | 1          |
| P-6      | <b>69Q-6</b>               | Washer—compression .....   | 1           | 1           | 1          | 1          |
| P-7      | <b>54Q-20</b>              | Insert—dome .....  | 1           | 1           | 1          | 1          |
| P-8      | <b>30-463-9</b>            | “O” ring—dome seal .....   | 1           | 1           | 1          | 1          |
| P-9      | <b>25Q-1701-20</b>         | Shift lever—straight .30" .....  | —           | 1           | —          | —          |
|          | <b>25Q-1701-49</b>         | Shift lever—straight .33" .....  | —           | —           | 1          | —          |
|          | <b>25Q-2461</b>            | Shift lever—lower end (RVI) .....                                      | —           | —           | —          | 1          |
|          | <b>25Q-2464</b>            | Shift lever—lower end .....  | 1           | —           | —          | —          |
| P-10     | <b>53Q-15</b>              | Shaft—rock .....   | 1           | 1           | 1          | 1          |
| P-11     | <b>40-17-1</b>             | Dome—shift lever (overall height 2") .....                             | 1           | 1           | —          | —          |
|          | <b>40-17-3</b>             | Dome—shift lever (overall height 3.31") .....                          | —           | —           | 1          | 1          |
| P-12     | <b>545028</b>              | Bolt—shift tower (7/16" -14 x 1 1/4") (not included in assembly) ..... | —           | 4           | 4          | 4          |
| or       | <b>545028-1</b>            | Bolt—shift tower (7/16" -14 x 1 3/4") ..                               | 4           | —           | —          | —          |
| P-13     | <b>40-155-1</b> (01-118-1) | Gasket—tower .....   | 2           | 1           | 1          | 1          |
| P-14     | <b>49-37-6</b>             | Spacer—tower (.445") .....   | 1           | —           | —          | —          |

313722-2X  
313723-2X



# MODEL CM49

**SPICER®**



**T210-CM49**

## CLUTCH RELEASE CODE TABLE

| Rel.Code<br>See Tab Bill | CR-7<br>Yoke ★ | Shaft      |           | CR-6 Pedal<br>Adjusting Arm | Rel.Code<br>See Tab Bill | CR-7<br>Yoke ★ | Shaft      |           | CR-6 Pedal<br>Adjusting Arm |
|--------------------------|----------------|------------|-----------|-----------------------------|--------------------------|----------------|------------|-----------|-----------------------------|
|                          |                | CR-1 Short | CR-2 Long |                             |                          |                | CR-1 Short | CR-2 Long |                             |
| 1                        | 105C-64        | 106C-1142  | 106C-1047 | 310233X                     | 58                       | 105C-137       | 106C-1141  | 106C-1169 | 310233X                     |
| 2                        | 105C-64        | 106C-1185  | 106C-438  | —                           | 59                       | 105C-137       | 106C-1185  | 106C-438  | —                           |
| 3                        | 105C-64        | 106C-1185  | 106C-939  | 310233X                     | 60                       | 105C-137       | 106C-1185  | 106C-617  | 310233X                     |
| 4                        | 105C-64        | 106C-1185  | 106C-1046 | 310233X                     | 61                       | 105C-137       | 106C-1185  | 106C-839  | 310233X                     |
| 5                        | 105C-64■       | 106C-1185  | 106C-1047 | 310233X                     | 62                       | 105C-137       | 106C-1185  | 106C-939  | 310233X                     |
| 6                        | 105C-64■       | 106C-1185  | 106C-1047 | 47-526-1-1X                 | 63                       | 105C-137       | 106C-1185  | 106C-939  | 310473X                     |
| 7                        | 105C-64■       | 106C-1544  | 106C-839  | 310233X                     | 64                       | 105C-137       | 106C-1185  | 106C-953  | 310473X                     |
|                          |                |            |           |                             | 65                       | 105C-137       | 106C-1185  | 106C-1046 | 310233X                     |
| 8                        | 105C-68        | 106C-1142  | 106C-438  | —                           | 66                       | 105C-137       | 106C-1185  | 106C-1046 | 310473X                     |
| 9                        | 105C-68        | 106C-1142  | 106C-617  | —                           | 67                       | 105C-137       | 106C-1185  | 106C-1047 | 310233X                     |
| 10                       | 105C-68        | 106C-1142  | 106C-617  | 310233X                     | 68                       | 105C-137       | 106C-1185  | 106C-1083 | 310233X                     |
| 11                       | 105C-68        | 106C-1142  | 106C-839  | 310233X                     | 69                       | 105C-137       | 106C-1185  | 106C-1094 | —                           |
| 12                       | 105C-68        | 106C-1142  | 106C-939  | 310233X                     | 70                       | 105C-137       | 106C-1185  | 106C-1094 | 310233X                     |
| 13                       | 105C-68        | 106C-1142  | 106C-1046 | 310233X                     | 71                       | 105C-137       | 106C-1185  | 106C-1123 | —                           |
| 14                       | 105C-68        | 106C-1142  | 106C-1047 | 310233X                     | 72                       | 105C-137       | 106C-1185  | 106C-1123 | 310233X                     |
| 15                       | 105C-68        | 106C-1278  | 106C-438  | —                           | 73                       | 105C-137       | 106C-1185  | 106C-1367 | —                           |
|                          |                |            |           |                             | 74                       | 105C-137       | 106C-1185  | 106C-1367 | 310233X                     |
| 16                       | 105C-117       | 106C-1071  | 106C-939  | 310233X                     | 75                       | 105C-137       | 106C-1185  | 106C-1375 | 310873X                     |
| 17                       | 105C-117       | 106C-1071  | 106C-1094 | 310233X                     | 76                       | 105C-137       | 106C-1185  | 106C-1515 | —                           |
| 18                       | 105C-117       | 106C-1142  | 106C-939  | 310233X                     | 77                       | 105C-137       | 106C-1185  | 106C-1529 | —                           |
| 19                       | 105C-117       | 106C-1185  | 106C-438  | —                           | 78                       | 105C-137       | 106C-1185  | 330610-5  | —                           |
| 20                       | 105C-117       | 106C-1185  | 106C-617  | 310233X                     | 79                       | 105C-137       | 106C-1216  | 106C-617  | 310233X                     |
| 21                       | 105C-117       | 106C-1185  | 106C-839  | 47-526-1-1X                 | 80                       | 105C-137       | 106C-1278  | 106C-438  | —                           |
| 22                       | 105C-117       | 106C-1185  | 106C-939  | 310233X                     | 81                       | 105C-137       | 106C-1278  | 106C-588  | —                           |
| 23                       | 105C-117       | 106C-1185  | 106C-953  | 310873X                     | 82                       | 105C-137       | 106C-1278  | 106C-588  | 310233X                     |
| 24                       | 105C-117       | 106C-1185  | 106C-960  | 310233X                     | 83                       | 105C-137       | 106C-1278  | 106C-617  | 310233X                     |
| 25                       | 105C-117       | 106C-1185  | 106C-1046 | 310233X                     | 84                       | 105C-137       | 106C-1278  | 106C-939  | 310233X                     |
| 26                       | 105C-117       | 106C-1185  | 106C-1047 | 310233X                     | 85                       | 105C-137       | 106C-1278  | 106C-939  | 310873X                     |
| 27                       | 105C-117       | 106C-1185  | 106C-1083 | —                           | 86                       | 105C-137       | 106C-1278  | 106C-960  | 310233X                     |
| 28                       | 105C-117       | 106C-1185  | 106C-1083 | 310233X                     | 87                       | 105C-137       | 106C-1278  | 106C-1046 | —                           |
| 29                       | 105C-117       | 106C-1185  | 106C-1083 | 310473X                     | 88                       | 105C-137       | 106C-1278  | 106C-1046 | 310233X                     |
| 30                       | 105C-117       | 106C-1185  | 106C-1094 | 310233X                     | 89                       | 105C-137       | 106C-1278  | 106C-1047 | —                           |
| 31                       | 105C-117       | 106C-1185  | 106C-1094 | 310873X                     | 90                       | 105C-137       | 106C-1278  | 106C-1047 | 310233X                     |
| 32                       | 105C-117       | 106C-1185  | 106C-1169 | 310233X                     | 91                       | 105C-137       | 106C-1278  | 106C-1083 | 310233X                     |
| 33                       | 105C-117       | 106C-1185  | 106C-1315 | —                           | 92                       | 105C-137       | 106C-1278  | 106C-1094 | 310233X                     |
| 34                       | 105C-117       | 106C-1185  | 106C-1315 | 310233X                     | 93                       | 105C-137       | 106C-1278  | 106C-1375 | 310233X                     |
| 35                       | 105C-117       | 106C-1185  | 106C-1315 | 47-526-1-1X                 | 94                       | 105C-137       | 106C-1278  | 106C-1422 | 310233X                     |
| 36                       | 105C-117       | 106C-1185  | 106C-1417 | 310233X                     | 95                       | 105C-137       | 106C-1278  | 106C-1529 | —                           |
| 37                       | 105C-117       | 106C-1185  | 106C-1417 | 310873X                     | 96                       | 105C-137       | 106C-1360  | 106C-1083 | —                           |
| 38                       | 105C-117       | 106C-1185  | 106C-1490 | 310233X                     | 97                       | 105C-137       | 106C-1360  | 106C-1422 | 310233X                     |
| 39                       | 105C-117       | 106C-1278  | 106C-939  | 310233X                     | 98                       | 105C-137       | 106C-1375  | 106C-438  | 310233X                     |
| 40                       | 105C-117       | 106C-1278  | 106C-960  | 310873X                     | 99                       | 105C-137       | 106C-1498  | 106C-438  | —                           |
| 41                       | 105C-117       | 106C-1278  | 106C-1047 | 310233X                     | 100                      | 105C-137       | 106C-1498  | 106C-617  | 310233X                     |
| 42                       | 105C-117       | 106C-1278  | 106C-1094 | 310233X                     | 101                      | 105C-137       | 106C-1498  | 106C-617  | 310473X                     |
| 43                       | 105C-117       | 106C-1278  | 106C-1315 | 310233X                     | 102                      | 105C-137       | 106C-1498  | 106C-939  | 310233X                     |
| 44                       | 105C-117       | 106C-1278  | 106C-1367 | 310233X                     | 103                      | 105C-137       | 106C-1498  | 106C-939  | 310473X                     |
| 45                       | 105C-117       | 106C-1360  | 106C-1083 | 310233X                     | 104                      | 105C-137       | 106C-1498  | 106C-953  | 310233X                     |
| 46                       | 105C-117       | 106C-1360  | 106C-1315 | 310233X                     | 105                      | 105C-137       | 106C-1498  | 106C-959  | 310233X                     |
| 47                       | 105C-117       | Thru Shaft | 106C-1550 | —                           | 106                      | 105C-137       | 106C-1498  | 106C-1046 | 310233X                     |
| 48                       | 105C-117       | Thru Shaft | 106C-1558 | —                           | 107                      | 105C-137       | 106C-1498  | 106C-1047 | —                           |
|                          |                |            |           |                             | 108                      | 105C-137       | 106C-1498  | 106C-1047 | 310233X                     |
| 49                       | 105C-124■      | 106C-1185  | 106C-438  | —                           | 109                      | 105C-137       | 106C-1498  | 106C-1083 | 310233X                     |
| 50                       | 105C-124■      | Thru Shaft | 106C-1566 | 310233X                     | 110                      | 105C-137       | 106C-1498  | 106C-1094 | —                           |
| 51                       | 105C-124■      | Thru Shaft | 106C-1566 | 310473X                     | 111                      | 105C-137       | 106C-1498  | 330610-11 | 310233X                     |
| 52                       | 105C-124■      | Thru Shaft | 106C-1566 | 310873X                     | 112                      | 105C-137       | 330601-1   | 106C-939  | 310233X                     |
| 52A                      | 105C-124■      | Thru Shaft | 49-510-1  | 310233X                     |                          |                |            |           |                             |
| 53                       | 105C-132       | 106C-1185  | 106C-1047 | 310233X                     | 113                      | 85-509-3       | 106C-1360  | 106C-1417 | 310233X                     |
| 54                       | 105C-132       | 106C-1185  | 106C-1083 | 310233X                     | 114                      | 85-509-3       | Thru Shaft | 106C-1578 | 310233X                     |
| 55                       | 105C-132       | 106C-1185  | 106C-1417 | 310873X                     | 115                      | 85-509-3       | Thru Shaft | 106C-1578 | 310873X                     |
| 56                       | 105C-132       | 106C-1185  | 46-510-9  | —                           |                          |                |            |           |                             |
| 57                       | 105C-132       | 106C-1278  | 46-510-9  | —                           | 116                      | 312916         | Thru Shaft | 97-510-2  | —                           |

■ Use Clutch Release Bearing 7743X & (2) 230C-12 SPRINGS

★ CLUTCH RELEASE YOKE ATTACHING PARTS—Use one KEY 10-30, two SCREWS 330231 and two LOCK WASHERS 500356-12

PARTS LISTED IN THIS CATALOG MAY NO LONGER BE AVAILABLE, USE WITH TRANSMISSION SUPERSEDING LIST.

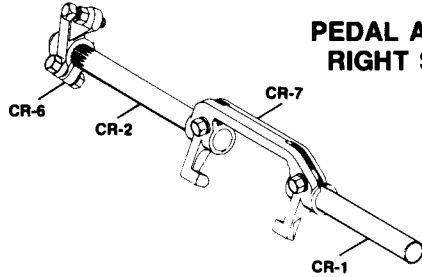

**PEDAL ADJUSTING ARM  
RIGHT SIDE—310473X**

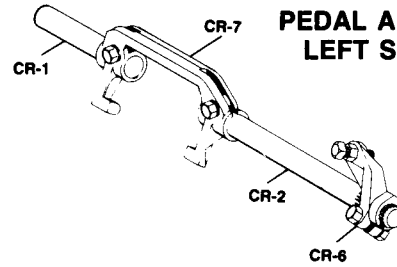

**PEDAL ADJUSTING ARM  
LEFT SIDE—310233X**

**CR-1 SHORT SHAFT**

| Part No.  | Length |
|-----------|--------|
| 106C-1071 | 4.062" |
| 106C-1141 | 5.125" |
| 106C-1142 | 6.125" |
| 106C-1185 | 5.750" |
| 106C-1216 | 4.750" |
| 106C-1278 | 4.812" |
| 106C-1360 | 5.312" |
| 106C-1375 | 6.781" |
| 106C-1498 | 6.500" |
| 106C-1544 | 7.000" |
| 330601-1  | 6.250" |

**CR-2 LONG SHAFT (Cont'd)**

| Part No.  | Type | Length  |
|-----------|------|---------|
| 106C-1083 | RS-8 | 7.969"  |
| 106C-1094 | RS-8 | 8.469"  |
| 106C-1123 | RS-8 | 12.968" |
| 106C-1169 | RS-8 | 9.125"  |
| 106C-1315 | RS-8 | 7.625"  |
| 106C-1367 | RS-8 | 10.312" |
| 106C-1375 | RS-8 | 6.781"  |
| 106C-1417 | RS-8 | 7.250"  |
| 106C-1422 | RS-8 | 7.500"  |
| 106C-1490 | RS-8 | 16.000" |
| 106C-1515 | RS-5 | 11.375" |
| 106C-1529 | RS-5 | 8.312"  |
| 330610-5  | RS-8 | 9.469"  |
| 330610-11 | RS-8 | 10.750" |
| 46-510-9  | RS-5 | 7.125"  |



**CR-2 LONG SHAFT**

| Part No.  | Type | Length  |
|-----------|------|---------|
| 106C-438  | RS-5 | 14.000" |
| 106C-588  | RS-5 | 7.000"  |
| 106C-617  | RS-8 | 10.469" |
| 106C-839  | RS-8 | 11.469" |
| 106C-939  | RS-8 | 10.000" |
| 106C-953  | RS-8 | 9.750"  |
| 106C-959  | RS-8 | 11.968" |
| 106C-960  | RS-8 | 8.719"  |
| 106C-1046 | RS-8 | 8.968"  |
| 106C-1047 | RS-8 | 9.469"  |

**CR-6 PEDAL ADJ. ARM**

- 310233X For Left Side Mtg.
  - 310473X For Right Side Mtg.
  - 47-526-1-1X ■ Lever Type 7/4"
  - 310873X ■ Lever Type 7/4"
- Lever type can be used on either right or left side.

**THRU SHAFT (used with Push Type Clutch)**

| Part No.  | Type    | Length  |
|-----------|---------|---------|
| 106C-1566 | Splined | 19.125" |
| 106C-1550 | Keyed   | 16.375" |
| 106C-1558 | Keyed   | 19.000" |
| 106C-1578 | Splined | 19.500" |
| 49-510-1  | Keyed   | 19.120" |
| 97-510-2  | Splined | 19.313" |

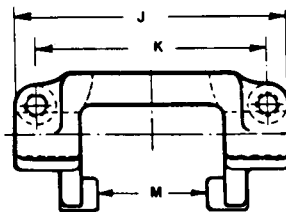

**CLUTCH RELEASE YOKES**

| CR-7                  | Forging No. | Used With             | Type | J      | K      | M      |
|-----------------------|-------------|-----------------------|------|--------|--------|--------|
| 105C-64               | F105C64     | Spicer 15 1/2" SP     | Pull | 8.000" | 6.500" | 4.895" |
| 105C-68               | F105C99     | Spicer 14" SP         | Pull | 7.125" | 5.750" | 4.132" |
| 105C-117 <sup>1</sup> | F105C118    | Spicer & Others       | Push | 8.375" | 7.000" | 4.885" |
| 105C-124 ■            | F105C125    | Spicer AL & AR        | Push | 3.750" | 2.125" | 2.885" |
| 105C-132 <sup>2</sup> | F105C118    | Spicer & Others       | Push | 8.375" | 7.000" | 4.885" |
| 105C-137              | F105C138    | Spicer 13" and 14" 2P | Pull | 8.000" | 6.500" | 4.895" |
| 85-509-3 <sup>3</sup> | F105C118    | Spicer & Others       | Push | 8.375" | 7.000" | 4.885" |

<sup>1</sup>Machined washer surface on yoke front

<sup>2</sup>Machined washer surface on yoke rear (for clearance)

<sup>3</sup>Same as <sup>1</sup> above except contains spring holes in lugs

■ Use 7743X Clutch Release Bearing & (2) 230C-12 SPRINGS

★ CLUTCH RELEASE YOKE ATTACHING PARTS—

Use one KEY 10-30, two SCREWS 330231 and two LOCK WASHERS 500356-12

NOTE: When changing from a two plate to single plate clutch or vice versa, a different bearing cap will be required.

PARTS LISTED IN THIS CATALOG MAY NO LONGER BE AVAILABLE, USE WITH TRANSMISSION SUPERSEDING LIST.

# MODEL CM49

## OVERHAUL KITS



T210-CM49

| Part Number                             | Part Description                                    | Qty. |
|---|---|------|
| <b>MAJOR OVERHAUL KIT</b>               |   |      |
| 313400-67X                              | Major Overhaul Kit .....                            | 1    |
| 501200                                  | Nut—mainshaft output .....                          | 1    |
| 53-205-1                                | Washer—mainshaft nut .....                          | 1    |
| 313401-29X                              | Thrust Washer Kit .....                             | 1    |
| 313429-7X                               | Shifter Housing Small Parts Kit .....               | 1    |
| 313432-30X                              | Minor Overhaul kit .....                            | 1    |
| <b>MINOR OVERALL KIT</b>                |   |      |
| <b>(Included in MAJOR OVERHAUL KIT)</b> |   |      |
| 313432-30X                              | Minor Overhaul Kit .....                            | 1    |
| <b>BEARINGS</b>                         |   |      |
| 550986                                  | Mainshaft Pocket .....                              | 1    |
| 550989                                  | Mainshaft Rear Cone .....                           | 1    |
| 550988                                  | Drive Gear Front .....                              | 1    |
| 550963                                  | Mainshaft 2nd & reverse .....                       | 2    |
| 550886                                  | Reverse Idler Gear .....                            | 2    |
| 550964                                  | Countershaft Front—cone .....                       | 1    |
| 550965                                  | Countershaft Front—cup .....                        | 1    |
| 550868                                  | Countershaft Rear—cone .....                        | 1    |
| 550978                                  | Countershaft Rear—cup .....                         | 1    |
| 550968                                  | Mainshaft 3rd Needle .....                          | 1    |
| 550991                                  | Mainshaft 1st Speed .....                           | 1    |
| 550990                                  | Mainshaft 4th Speed .....                           | 1    |
| 40-486-1                                | Clip—shift fork; (4th & 5th) .....                  | 2    |
| 49-486-2                                | Clip—shift fork (1st & reverse) (2nd & 3rd) .....   | 4    |
| 49-486-3                                | Clip—shift fork (1st & reverse) (2nd & 3rd) .....   | 4    |
| 40-463-4-1X                             | Seal—drive gear (flat type) .....                   | 1    |
| 40-463-6-1X                             | Seal—drive gear (stem type) .....                   | 1    |
| 63-463-1                                | Seal-mainshaft rear .....                           | 1    |
| 545077                                  | #2 Moly Grease (packet) .....                       | 1    |
| 545080-1                                | Locite—Threadlock Adhesive (vail) .....             | 1    |
| 312475-40X                              | Gasket Kit .....                                    | 1    |
| 313438-3X                               | Shim Kit—countershaft rear .....                    | 1    |
| 313024-17X                              | Snap Ring—kit .....                                 | 1    |
| 2359                                    | Service Manual .....                                | 1    |
| 2770                                    | Bulletin—bearing lube instruction .....             | 1    |
| 2783                                    | Bulletin—locite application for mainshaft nut ..... | 1    |
| <b>(Included in MAJOR OVERHAUL KIT)</b> |   |      |
| 313401-29X                              | <b>THRUST WASHER KIT</b> .....                      | 1    |
| 974-W                                   | Reverse Idler .....                                 | 2    |
| 49-47-2                                 | Mainshaft—3rd & 4th speed .....                     | 1    |
| 49-47-1                                 | Mainshaft—1st & 2nd speed .....                     | 1    |
| 49-47-3                                 | Mainshaft—reverse .....                             | 1    |
| 545087                                  | Pin-lock .....                                      | 2    |
| 313429-7X                               | <b>SHIFTER HOUSING SMALL PARTS</b> .....            | 1    |
| 40-80-1                                 | Poppet Ball .....                                   | 3    |
| 40-487-1                                | Insert—poppet spring and ball .....                 | 3    |
| 40-438-1                                | Pin-1st and reverse select plunger .....            | 1    |
| 97-72-23                                | Spring—shift bar poppet .....                       | 3    |
| 62-72-8                                 | Spring—1st & reverse shift finger plunger .....     | 1    |



| Part No.           | Part Description   | Qty. |
|--------------------|--|------|
|                    | <b>(Included in MINOR OVERHAUL KIT)</b>                      |      |
| 312475-40X         | GASKET KIT .....   | 1    |
| 40-223-1           | Mainshaft Rear Bearing Cap .....                             | 1    |
| 40-223-3           | Mainshaft Rear Bearing Cap (D.C.M. Brake) .....              | 1    |
| 97-324-1-1X        | P.T.O. Aperture Cover .....                                  | 2    |
| 49-324-1-1X        | Reverse Idler Cover .....                                    | 1    |
| 40-155-1 101-118-1 | Tower .....  | 1    |
| 545056-9           | Anaerobic Sealant .....                                      | 1    |
| 2792               | Bulletin—liquid gasket .....                                 | 1    |
| 313024-17X         | SNAP RING KIT .....  | 1    |
| 40-381-3           | Mainshaft 3rd & 4th Thrust Washer .....                      | 1    |
| 40-381-3           | Countershaft Head End Gear .....                             | 1    |
| 40-381-4           | Mainshaft 2nd & 3rd Clutch Gear .....                        | 1    |
| 49-381-1           | Mainshaft 1st & 2nd Thrust Washer .....                      | 1    |
| 27-381-5           | Countershaft 4th Gear .....                                  | 1    |
| 97-381-30          | Mainshaft Front Bearing .....                                | 1    |
| 40-381-1           | 4th & 5th Clutch Gear .....                                  | 1    |
| 313438-3X          | SHIM KIT .....   | 1    |
| 49-228-1-3         | Countershaft Rear Bearing (.0165/.0135) .....                | 1    |
| 49-228-1-2         | Countershaft Rear Bearing (.0110/.0090) .....                | 1    |
| 49-228-1-1         | Countershaft Rear Bearing (.0055/.0045) .....                | 1    |
| 2793               | Bulletin—countershaft shim kit .....                         | 1    |
| 40-463-4-1X        | SUB ASSEMBLY—oil seal & installation sleeve (flat cap) ..... | 1    |
| 2819               | Bulletin—oil seal installation instruction .....             | 1    |
| 40-463-4           | Seal—drive gear bearing cap .....                            | 1    |
| 40-204-1           | Sleeve—oil seal installation (1.75 diameter shaft) .....     | 1    |
| 40-463-6-1X        | SUB ASSEMBLY—oil seal & installation sleeve (stem cap) ..... | 1    |
| 2819               | Bulletin—oil seal installation instruction .....             | 1    |
| 40-463-6           | Seal—drive gear bearing cap .....                            | 1    |
| 40-204-2           | Sleeve—oil seal installation (1.500 diameter) .....          | 1    |
| 40-204-3           | Sleeve—oil seal installation (1.375 diameter) .....          | 1    |
| 97-324-1-1X        | KIT—gasket 6 bolt P.T.O. ....                                | 1    |
| 97-324-1           | Gasket—P.T.O. aperture cover .....                           | 1    |
| 330950             | Tag—instruction (service gaskets) .....                      | 1    |
|                    | <b>(Included in MAJOR OVERHAUL KIT)</b>                      |      |
| 49-324-1-1X        | KIT—gasket—reverse idler cover .....                         | 1    |
| 49-324-1           | Gasket—reverse idler cover .....                             | 1    |
| 330950             | Tag—instruction (service gaskets) .....                      | 1    |
| 313614-1X          | KIT—2nd & 3rd shift fork & bar with clips .....              | 1    |
| 313614X            | Sub Assembly—2nd & 3rd shift fork & bar .....                | 1    |
| 49-486-3           | Clip—1st reverse & 2nd, 3rd shift fork .....                 | 2    |
| 313614-2X          | KIT—2nd & 3rd shift fork & bar with synchronizer .....       | 1    |
| 313614-1X          | Kit—2nd & 3rd shift fork & bar with clip .....               | 1    |
| 313616X            | Synchronizer—2nd & 3rd .....                                 | 1    |
| 313615-2X          | KIT—1st & reverse shift bar with clips & collar .....        | 1    |
| 313615-3X          | Kit—1st & reverse shift bar & clips .....                    | 1    |
| 49-465-7           | Collar—1st & reverse .....                                   | 1    |
| 313615-3X          | KIT—1st & reverse shift bar & clips .....                    | 1    |
| 313615X            | Sub Assembly—1st & reverse shift fork & bar .....            | 1    |
| 49-486-3           | Clip—1st reverse & 2nd, 3rd shift fork .....                 | 2    |

# MODEL CM49

**SPICER®**



**T210-CM49**

## TABULATED BILLS OF MATERIAL

| Tab No.             | Used By        | For Use With Clutch 13" or 14" Single or 2PL | CLUTCH HOUSING |                     |           | Main Drive Gear<br>A-1 | Drive Gear Bearing Cap<br>F-1 | Main Case Assembly<br>G-1 |
|---------------------|----------------|--|----------------|---------------------|-----------|------------------------|-------------------------------|---------------------------|
|                     |                |  | S<br>A<br>E    | Assembly No.<br>E-1 | Rel. Code |                        |                               |                           |
| <b>Model 4954-A</b> |                |  |                |                     |           |                        |                               |                           |
| <b>301386</b>       |                |  |                |                     |           |                        |                               |                           |
| -1                  | Ford           | Push Type                                    | 2              | 49-518-4-2X         | —         | 49-35-3-1X             | 40-19-1-1X                    | 49-15-1-1X                |
| -2                  | Blue Bird Body | Push Type                                    | 2              | 49-518-5-2X         | 56        | 49-35-3-1X             | 40-19-1-1X                    | 49-15-1-1X                |
| -3                  | Spicer France  | Push Type                                    | 2              | 49-518-6-1X         | —         | 49-35-4-1X             | 40-19-32-1X                   | 49-15-1-1X                |
| -4                  | Spicer France  | Push Type                                    | 2              | 49-518-6-1X         | —         | 49-35-4-1X             | 40-19-32-1X                   | 49-15-1-1X                |
| -5                  | Blue Bird Body | Push Type                                    | 2              | 49-518-4-2X         | 52A       | 49-35-3-1X             | 40-19-24-1X                   | 49-15-4-1X                |
| -6                  | Navistar       | Pull Type                                    | 2              | 49-518-5-2X         | —         | 49-35-8-1X             | 40-19-40-1X                   | 49-15-4-1X                |
| -7                  | Spicer France  | Push Type                                    | 2              | 49-518-6-1X         | —         | 49-35-4-1X             | 40-19-32-1X                   | 49-15-1-1X                |
| -8                  | Spicer France  | Push Type                                    | 2              | 49-518-6-1X         | —         | 49-35-4-1X             | 40-19-32-1X                   | 49-15-1-1X                |
| -9                  | Spicer France  | Push Type                                    | 2              | 49-518-6-1X         | —         | 49-35-6-1X             | 40-19-32-1X                   | 49-15-1-1X                |
| -10                 | Navistar       | Pull Type                                    | 2              | 49-518-5-2X         | —         | 49-35-8-1X             | 40-19-40-1X                   | 49-15-4-1X                |
| -11                 | Ford           | Push Type                                    | 2              | 49-518-4-2X         | —         | 49-35-3-1X             | 40-19-1-1X                    | 49-15-1-1X                |
| <b>Model 4954-D</b> |                |  |                |                     |           |                        |                               |                           |
| <b>301387</b>       |                |  |                |                     |           |                        |                               |                           |
| -1                  | Navistar       | Push Type                                    | 2              | 49-518-5-2X         | —         | 49-35-3-1X             | 40-19-35-1X                   | 49-15-4-1X                |
| -2                  | Navistar       | Pull Type                                    | 2              | 49-518-5-2X         | —         | 49-35-8-1X             | 40-19-40-1X                   | 49-15-4-1X                |
| -3                  | Navistar       | Pull Type                                    | 2              | 49-518-5-2X         | —         | 49-35-8-1X             | 40-19-40-1X                   | 49-15-4-1X                |
| -4                  | Navistar       | Push Type                                    | 2              | 49-518-5-2X         | —         | 49-35-3-1X             | 40-19-35-1X                   | 49-15-4-1X                |
| -5                  | Navistar       | Push Type                                    | 2              | 49-518-5-2X         | —         | 49-35-3-1X             | 40-19-35-1X                   | 49-15-4-1X                |
| -6                  | Famsa          | Pull Type                                    | 2              | 49-518-5-2X         | 3         | 49-35-8-1X             | 40-19-40-1X                   | 49-15-4-1X                |
| -7                  | Spicer France  | Push Type                                    | 2              | 49-518-6-1X         | —         | 49-35-4-1X             | 40-19-32-1X                   | 49-15-1-1X                |
| -8                  | Spicer France  | Push Type                                    | 2              | 49-518-6-1X         | —         | 49-35-4-1X             | 40-19-32-1X                   | 49-15-1-1X                |
| -9                  | Australia      | Pull Type                                    | 2              | 49-518-5-2X         | —         | 49-35-6-1X             | 40-19-40-1X                   | 49-15-1-1X                |
| -10                 | Spicer France  | Push Type                                    | 2              | 49-518-6-1X         | —         | 49-35-4-1X             | 40-19-32-1X                   | 49-15-1-1X                |
| -11                 | Spicer France  | Push Type                                    | 2              | 49-518-6-1X         | —         | 49-35-4-1X             | 40-19-32-1X                   | 49-15-1-1X                |
| -12                 | Spicer France  | Push Type                                    | 2              | 49-518-6-1X         | —         | 49-35-4-1X             | 40-19-32-1X                   | 49-15-1-1X                |
| -13                 | Navistar       | Pull Type                                    | 2              | 49-518-5-2X         | —         | 49-35-8-1X             | 40-19-40-1X                   | 49-15-4-1X                |
| -14                 | Navistar       | Pull Type                                    | 2              | 49-518-5-2X         | —         | 49-35-8-1X             | 40-19-40-1X                   | 49-15-4-1X                |
| -15                 | Navistar       | Pull Type                                    | 2              | 49-518-5-2X         | —         | 49-35-8-1X             | 40-19-40-1X                   | 49-15-4-1X                |



# MODEL CM49

## TABULATED BILLS OF MATERIAL

T210-CM49

| Tab No. | Rear Bearing Cap Assembly<br>Cap, Seal and Bushing<br>H-1 | SPEEDOMETER                   |                       | End Yoke or<br>Companion<br>Flange<br>(page 13) | SHIFTER                            |                                |
|---------|---|-------------------------------|-----------------------|---|------------------------------------|--------------------------------|
|         |   | Drive<br>Gear<br>B-23<br>B-24 | Driven<br>Gear<br>H-8 |   | Lever &<br>Dome Ass'y<br>(page 15) | Remote<br>Control<br>(page 17) |

**Model 4954-A  
301386**

|     |             |          |          |            |             |            |
|-----|-------------|----------|----------|------------|-------------|------------|
| -1  | 40-19-39-1X | —        | —        | —          | —           | —          |
| -2  | 40-19-39-1X | 53-452-3 | 62-453-4 | —          | —           | —          |
| -3  | 40-19-38-2X | 53-452-4 | 53-453-2 | 5-4-6321-1 | 40-17-1-30X | —          |
| -4  | 40-19-38-2X | 53-452-4 | 53-453-2 | 4-4-4491   | 40-17-1-30X | —          |
| -5  | 40-19-22-2X | 53-452-3 | 62-453-4 | 3-4-8931-2 | —           | 40-18-1-2X |
| -6  | 40-19-19-2X | 53-452-3 | —        | —          | —           | —          |
| -7  | 40-19-38-2X | 53-452-4 | 53-453-2 | 5-4-6321-1 | —           | 40-18-1-7X |
| -8  | 40-19-38-2X | 53-452-4 | 53-453-2 | 5-4-6321   | 40-17-1-30X | —          |
| -9  | 40-19-38-2X | 53-452-4 | 53-453-2 | 5-4-6321   | —           | 40-18-1-7X |
| -10 | 40-19-38-2X | 53-452-3 | —        | —          | —           | —          |
| -11 | 40-19-39-1X | 53-452-6 | —        | 5-4-6481-1 | —           | —          |

**Model 4954-D  
301387**

|     |             |          |          |            |             |            |
|-----|-------------|----------|----------|------------|-------------|------------|
| -1  | 40-19-22-2X | 53-452-3 | —        | —          | —           | —          |
| -2  | 40-19-38-2X | 53-452-3 | —        | —          | —           | —          |
| -3  | 40-19-19-2X | 53-452-3 | —        | —          | —           | —          |
| -4  | 40-19-38-2X | 53-452-3 | —        | —          | —           | —          |
| -5  | 40-19-19-2X | 53-452-3 | —        | —          | —           | —          |
| -6  | 40-19-38-2X | 53-452-3 | 62-453-4 | 53-106-3   | 40-17-1-12X | —          |
| -7  | 40-19-38-2X | 53-452-4 | 53-453-2 | 5-4-6321-1 | 40-17-1-30X | —          |
| -8  | 40-19-38-2X | 53-452-4 | 53-453-2 | 4-4-4491   | 40-17-1-30X | —          |
| -9  | 40-19-38-2X | 53-452-4 | 53-453-2 | 4-4-4491-1 | —           | 40-18-1-6X |
| -10 | 40-19-38-2X | 53-452-4 | 53-453-2 | 5-4-6321-1 | —           | 40-18-1-7X |
| -11 | 40-19-38-2X | 53-452-4 | 53-453-2 | 5-4-6321   | 40-17-1-30X | —          |
| -12 | 40-19-38-2X | 53-452-4 | 53-453-2 | 5-4-6321   | —           | 40-18-1-7X |
| -13 | 40-19-22-2X | 53-452-3 | —        | —          | —           | —          |
| -14 | 40-19-41-2X | 53-452-5 | —        | —          | —           | —          |
| -15 | 40-19-43-2X | 53-452-5 | —        | —          | —           | —          |



14700 Helm Court  
Plymouth, MI 48170  
(800) 401-9866 or (734) 456-3770  
Fax: (734) 456-3739  
[www.ttcautomotive.com](http://www.ttcautomotive.com)

