

The background of the cover is a collection of various transmission components, including gears of different sizes, shafts, and yokes, arranged in a somewhat chaotic but organized manner. The lighting is warm, highlighting the metallic textures and the intricate details of the parts.

FAILURE ANALYSIS GUIDE

**TYPES AND CAUSES
ALL MODELS**

TTC TRANSMISSION
TECHNOLOGIES
Corporation

Technology in Motion®

Bulletin No. 2373

SAFETY FIRST

Carefully read this service manual before beginning any work on your Spicer transmission.

Throughout this literature, you will see symbols that warn of potential physical danger or product damage if the accompanying instructions aren't followed. Here are the symbols and their meanings.

 This symbol indicates a potentially hazardous situation which, if not corrected, could result in property damage, serious bodily injury or death.

 This symbol indicates that you must do something in order for the transmission to function properly. For example, you must align bearing caps with case oil grooves to assure proper unit lubrication and functioning.

Be sure you understand all procedures and instructions in this manual before you begin working on your Spicer transmission. If you have any questions, contact your Spicer Transmission representative.

General Safety Precautions

 **WARNING: Use a hoist when lifting the transmission or shaft assemblies.** Using a hoist can help prevent muscle strain or other possible injuries.

 **WARNING: Always wear safety glasses when working on a transmission.** This will help you prevent possible eye injury due to small parts (such as snap rings) or metal chips that may fly up unexpectedly during a teardown or rebuild.

 **WARNING: Be careful when picking up gears or other sharp components.** If you aren't careful, you could cut your hands. Consider wearing heavy cloth gloves or covering sharp objects with shop towels before picking them up.

 **WARNING: When draining the transmission prior to working on it, be careful to let the unit cool down first.** Otherwise, hot transmission fluid could cause burns.

 **WARNING: Bleed air from the system before working on this unit.** Otherwise, air pressure could cause air tubing to whip when the shift tower is disassembled, possibly cutting or otherwise injuring the mechanic or bystanders.

INTRODUCTION

Failure analysis is a highly technical field. Often it requires specialized knowledge and equipment to determine how and why a failure occurred. Yet there are many failures which can be readily identified and explained with a visual inspection if their characteristic appearances are known and recognized. These kinds of failures are the subject of this manual.

Of course, identification of a failure is just the beginning of a productive analysis procedure. It is equally important to know what caused the failure in the first place and what corrective action will ensure that it does not occur again.

A successful failure analysis, then, requires three steps:

1. Identify the type of failure.
2. Determine the cause of the failure.
3. Take corrective action to prevent a recurrence.

A Spicer technical support line is available to help you identify failures and their causes and suggest corrective action. For help call 1-800-666-8688.

Every effort has been made to ensure the accuracy of all information in this brochure. However, Dana Corporation makes no expressed or implied warranty or representation based on the information contained in this guide. Any errors or omissions should be reported to the Spicer Support Line 1-800-666-8688.

TABLE OF CONTENTS

Some Common Transmission Complaints	1 - 3
Hard Shifting	1
Gear Jumping	1
Vibration	2
Heat and Lubrication	2
Component Failures	4 - 13
Gears and Clutch Collars	4
Bearings	7
Forks	8
Synchronizers	9
Shafts	10
Seals	13
Non-Warrantable Conditions	14 - 15
Product Warranty	14
Normal Wear	14
Non-Warrantable Conditions	14
Glossary	16

The following statements and photographs of component failures represent quality Spicer parts subjected to abuse, poor maintenance procedures and/or misapplication. These failures do not illustrate defective Spicer components.

SOME COMMON TRANSMISSION COMPLAINTS

Hard Shifting

When hard shifting is reported, the first thing to be inspected is the clutch. An improperly operating clutch will interfere with the shifting of gears in any transmission. And don't overlook the obvious. Spicer transmissions require the correct lever ratio to shift properly. This ratio is calculated from the fulcrum both up and down. Synchronized transmissions require a shift lever ratio of 8 to 1 for proper shiftability.

Next, examine the remote control linkage for proper adjustment, worn bushings, bent rods or lack of lubrication. If none of these are the problem, remove the remote control from the transmission.

By removing the remote control and shifting the transmission into gear with a pry bar, you can determine whether the transmission is at fault. If the shift rods move readily into position, the trouble is somewhere in the external linkage. If not, consider these possible causes of hard shifting:

- Worn or bent shift rods or shift rails
 - Replace as necessary
- Broken springs or elongated poppet holes in shift cover
 - Replace springs, shift cover or both
- Clutch collars tight on mainshaft splines
 - Check for twisted mainshaft and replace
- Free running gears seized on either the thrust face or the shaft diameter
 - Use correct type of lubricant at the proper fill level
- Broken thrust washers or snap rings
 - Replace and check for vibration
- Excessive end play
 - Shim to correct end play
- Loose mainshaft nut
 - Torque to specified rating
- Worn or seized pilot bearing in flywheel
 - Replace worn or damaged components
 - Use correct lubricant
- Oxidized or overheated lubricant
 - Follow recommended lubrication procedures
- Metal particles imbedded in brass or GYLON®-coated synchronizer ring
 - Replace synchronizer
 - Check lubricant for contamination and replace
 - Check for other damage that could result from clash shifting

Gear Jumping

Gear jumping is caused by interference in the shifting mechanism or some other malfunction which results in the clutch gear or shift rod moving out of its selected position during operation.

When a problem occurs, inspect the shift lever first. Make certain it moves freely and completely into position. Also check the floorboard opening, driver's seat or anything that could prevent full clutch gear engagement. Other potential causes of gear jumping include:

- Heavy shift lever extensions
 - Use a shift lever that doesn't have a top-heavy extension
- Broken poppet springs
 - Replace
- Worn shift rod detents
 - Replace shift rod
- Bent or sprung shift rods or forks
 - Replace
- Worn clutching teeth on shift collars
 - Replace
 - Inspect mating components for damage
 - Make certain the driver knows and uses proper shifting techniques
- Broken thrust washers
 - Replace
- Broken snap rings
 - Replace
- Worn corners on mainshaft or clutch gear gearlocks
 - Replace
 - Inspect mating components for damage

Vibration

Vibration problems are often difficult to trace and isolate. While the effects of vibration will often cause transmission problems, the vibration itself usually originates somewhere else.

Intermittent vibration can be isolated under specific conditions of engine idle or RPM, gear selection, load and speed. Constant vibration should also vary with engine RPM, load and speed to provide clues to its source.

Some possible causes of vibration include:

- Loose output nut which is sometimes indicated by shiny areas on the output shaft (caused by yoke movement)
 - Tighten nut to specifications
 - Check output shaft for wear
- Rough idling engine
 - Use dampened disk clutch
- Loose or broken engine mounts
 - Replace

Sometimes vibration originates in the driveline. Potential causes include improper universal joint working angles, out-of-phase shafts, shafts that aren't balanced and excessive driveshaft lengths. If the driveline is the source of the vibration, these conditions must be corrected.

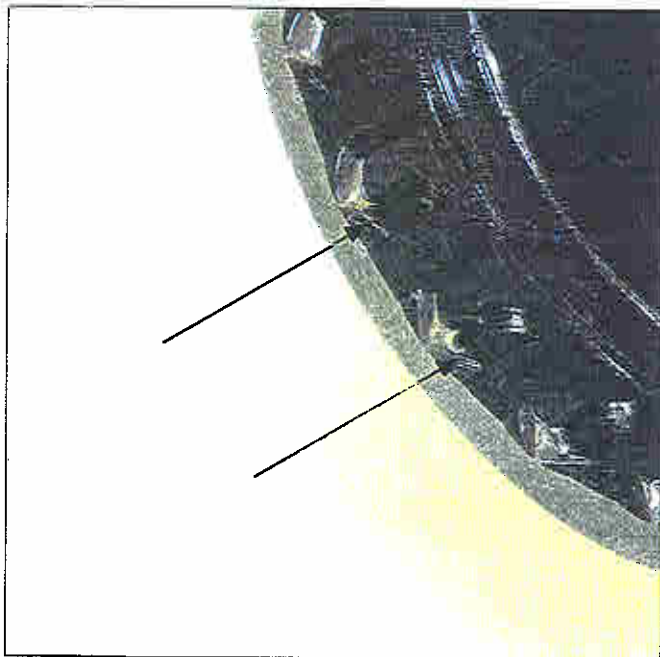

Figure 1—Torsional engine vibration could cause worn clutching teeth.

⚠ VIBRATION WARNING

Vibration can be an early indicator of a problem with the vehicle driveline. Potential causes of driveline vibration are excessive operating angles, out-of-phase shafts, unbalanced shafts, or excessive shaft lengths. These conditions must be corrected immediately. Driveline vibration can cause damage to the transmission and can also result in separation of the driveline from the vehicle. Separation of the driveline from the vehicle can result in serious bodily injury or death. In order to avoid driveline vibration, you must have the vehicle examined immediately by a qualified mechanic who is experienced with proper driveline application and installation.

Heat and Lubrication

A continuous operating temperature of 250° F should be considered as maximum for reasonable drain intervals. A rise in temperature of 20° F over 250° F doubles the oxidation rate, thus shortening the effective life of the oil. Short periods over 300° F don't indicate a transmission problem, but will still affect oil life.

SOME COMMON TRANSMISSION COMPLAINTS

Certain conditions can cause a temperature increase and, therefore, make an oil cooler necessary. These include:

- All direct main transmissions behind engines rated at 400 HP (gross) and above
- All overdrive main transmissions behind engines rated 350 HP (gross) and above
- All main transmissions (direct and overdrive) where vehicle GVW/GCW exceeds 90,000 lbs.
- All auxiliary transmissions where vehicle GVW/GCW exceeds 80,000 lbs.
- All auxiliary transmissions behind overdrive main transmissions regardless of engine horsepower
- Vehicle configurations that restrict air movement around the transmission (i.e., aero body configurations, low front bumpers, deck plates, skirting, or an exhaust pipe near the transmission)
- Any vehicle application that has high transmission shaft speed at low ground speed or runs above 250° F continuously
- Geographical locations in which the vehicle is to be operated, such as mountains, or in high ambient temperatures
- Transmissions running a PTO in a stationary application

LUBRICATION CAUTION

Proper lubrication of the transmission is critical to the life of the transmission and safe operation of the vehicle. Lubrication problems can result from too much lubricant, too little lubricant, or the wrong type of lubricant. Improper lubrication can result in excessive heat and seizure of the bearings in the transmission. A seizure of the bearings can cause the vehicle to lose power. In order to avoid these problems, it is important that the instructions for proper lubrication are carefully followed.

Proper Lubrication

Help your lubricant protect your equipment by following these guidelines.

- Always fill Spicer transmissions to the proper lubricant levels. Using too much lubricant causes it to churn, foam, and overheat. This prematurely breaks down the lubricant. Too little lubricant allows heat buildup and prevents adequate coating and protection of components. The lubricant should be level with the transmission oil fill plug.

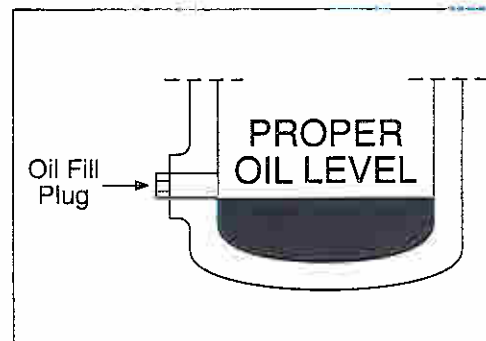

- Always follow the recommended grades and types of lubricant for your Spicer transmission. Never mix and match grades or types of lubricant: they may be incompatible. Lubricant specifications are published in Spicer service manuals.
- Always follow the recommended oil change schedule for your Spicer transmission.
- Use only quality lubricants.
- When changing oil, check it for contamination. If debris—especially metal chips—are found, it could be a sign of internal transmission damage. In any case, replace contaminated lubricant and further examine the unit if it is indicated.
- Check the angle of the transmission. Too steep an angle could prevent lubricant from reaching the input shaft pocket bearing.

Gears and Clutch Collars

As you examine a gear, you may notice hob marks, or "scallops," on the tip and root of the gear teeth. These are normal and acceptable machining marks. They do not indicate a problem with the gear (see Figure 2).

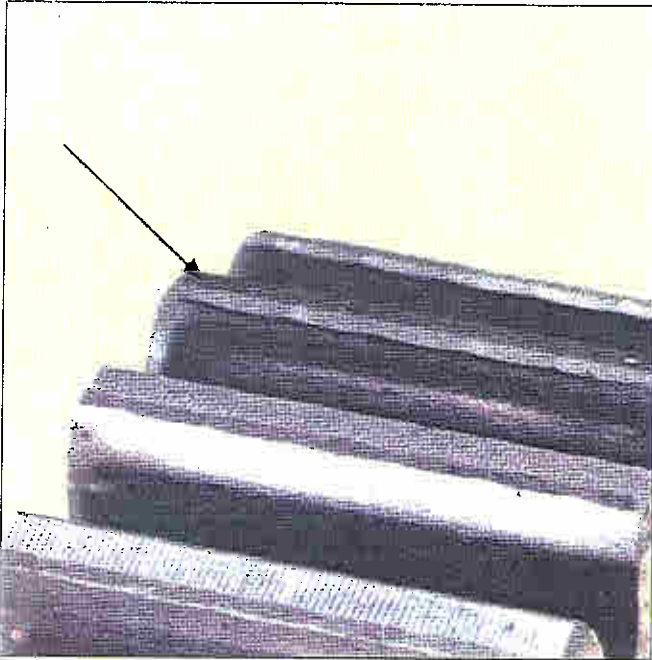

Figure 2—Hob marks are acceptable.

However, over time gear teeth will wear as they mesh with mating gear teeth. When the endurance limit of the gear material is exceeded, the result is pitting (see Figure 3). If a gear with pitting over 50% of its tooth surface is allowed to remain in service, it will eventually fracture.

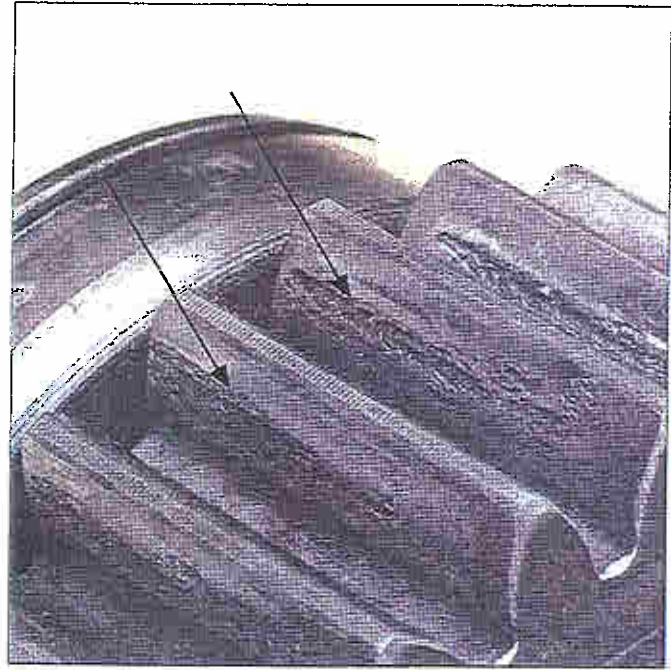

Figure 3—Pitting, scoring and galling can occur when the gear material endurance limit is exceeded. Lubrication problems can also contribute to these conditions.

Another contributor to pitting—as well as to scoring and galling—is improper lubrication. Improper lubrication refers to lubrication breakdown, improper lubricant levels, and contaminated lubrication.

Any breakdown of the lubrication, or reduced oil film, can increase the possibility or acceleration of tooth surface distress. More importantly, inadequate lubrication for a sustained period is likely to cause the distress to advance to more severe stages. Common causes of inadequate lubrication are:

- Low lube level
- Inadequate lube viscosity
- Use of incorrect lube
- Use of oil beyond its functional life

This can lead to alternate welding and tearing of metal from gear teeth surfaces (see Figure 3).

 See LUBRICATION CAUTION (pg. 3).

As the hardened gear teeth surfaces begin to wear away, failures arise. A sudden shockload failure shows clean break lines (see Figure 4).

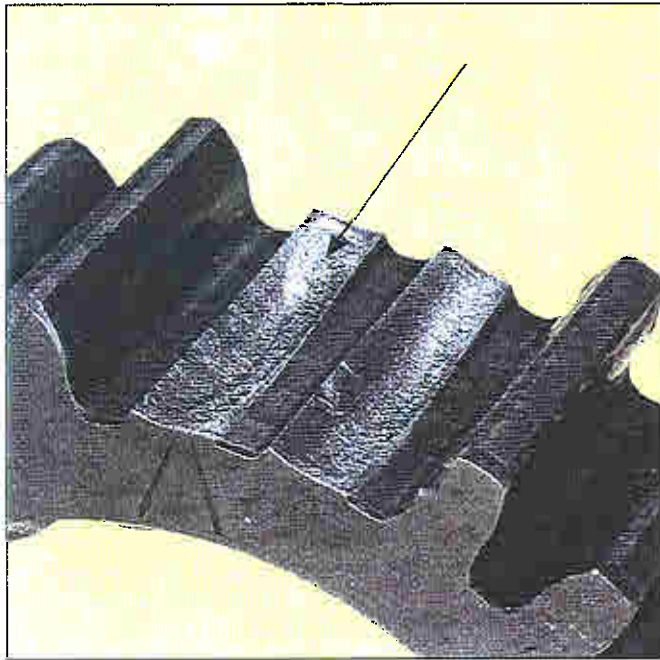

Figure 4—A clean break indicates a sudden shockload failure.

A gear failure that occurs over a longer period of time has "oyster shell" or "beach" marks. These marks look like the pattern ocean waves leave in sand (see Figure 5). Generally, bending forces on the gear teeth will create cracks in the tooth's surface. Over a period of time, the crack will continue to grow, causing a beach mark design fracture pattern. Finally, the tooth is weakened to the point where it breaks off. The surface of the failure is generally smooth and will have contoured lines which show how the failure progressed. A fatigue failure such as this is caused by loading the vehicle beyond its specified gross weight or by abusive operation on the vehicle on rough terrain.

Gear teeth that have rolled over are an additional sign of heat and lubrication problems. During a teardown, always inspect gears for signs of pitting, scoring, galling, cracks and rolled teeth. Replace any worn or damaged gears. If one gear shows signs of trouble, also check the mating gears for possible damage. Use a magnetic particle crack detection system to do this.



Figure 5—A beach mark signals a fatigue failure that has developed over time.

Along with lubrication problems and normal wear, another cause of gear damage is shockload. Shockload failures may occur immediately after the initial shock or at a later date. The mainshaft can also be damaged (see Figures 6 and 7).

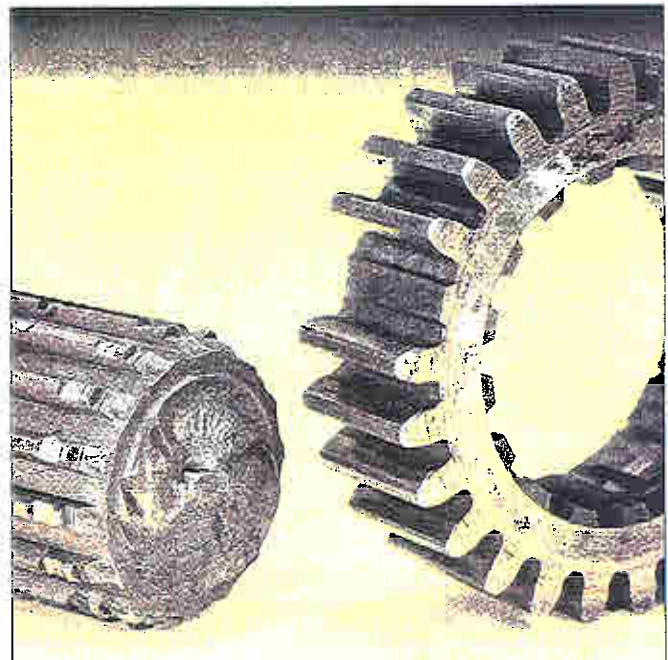

Figure 6—A broken shaft and missing gear teeth indicate shockload.

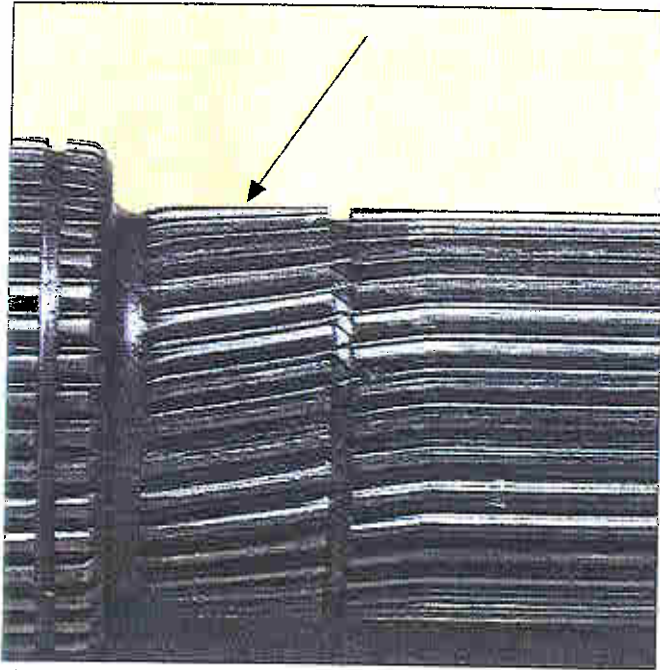

Figure 7—A twisted mainshaft indicates shockload.

A gear tooth that has broken below the root line is a good indicator of shockload. Usually, mating gears also show signs of the shockloading. Always replace the damaged gear and the mating gears, even if they do not look damaged. Also check the rest of the transmission for damage from the broken gear tooth traveling through the unit.

Common Causes of Shockload

- Starting in wrong gear, too high a gear
 - Review shifting procedures
 - Driver training
- Starting the vehicle while the brakes are still applied
 - Driver training
- Popping the clutch
 - Driver training
- Overloaded vehicle
 - Check gross vehicle weight specification
- Backing into a loading dock
 - Driver training
- Tires spinning then quickly gaining traction
 - Avoid spinning wheels if possible

A fourth common cause of gear failure is clash shifting. When a driver shifts a transmission before the engine and transmission speeds are matched (or before the synchronizer can do its job), a clutch collar is forced into gear. The result is worn clutching teeth that can lead to the transmission jumping out of gear (see Figures 8 and 9). Gears, collars, or shafts with worn clutching teeth or gearlocks should be replaced.

⚠ SHIFTING CAUTION

Improper shifting of the transmission will result in worn clutching teeth, which may lead to the transmission jumping out of gear. If the transmission jumps out of gear, there could be a loss of power. In order to avoid worn clutching teeth, you must: (1) assure that the driver receives training and adheres to proper driving techniques; (2) inspect the vehicle and replace any worn gears, collars or shafts.

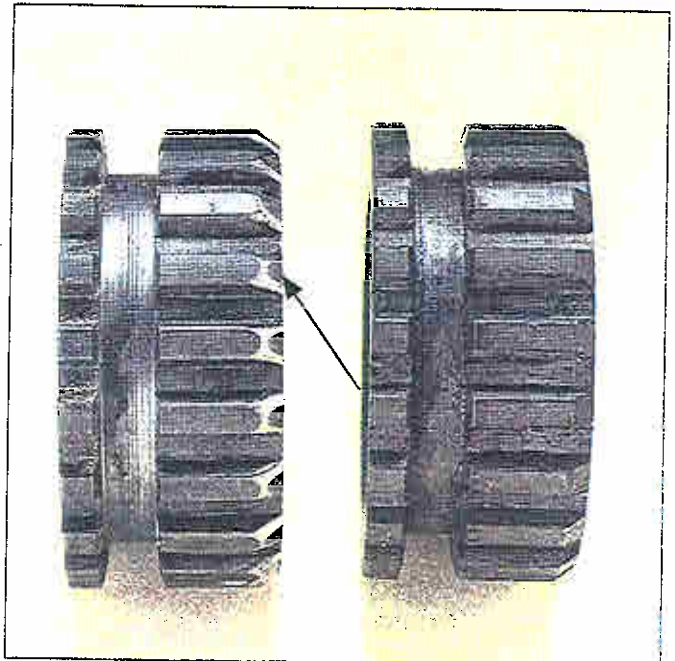

Figure 8—Failure to use the clutch can cause worn clutching teeth, a major cause of transmissions jumping out of gear. Shown here are worn clutching teeth (left) and new clutching teeth (right).

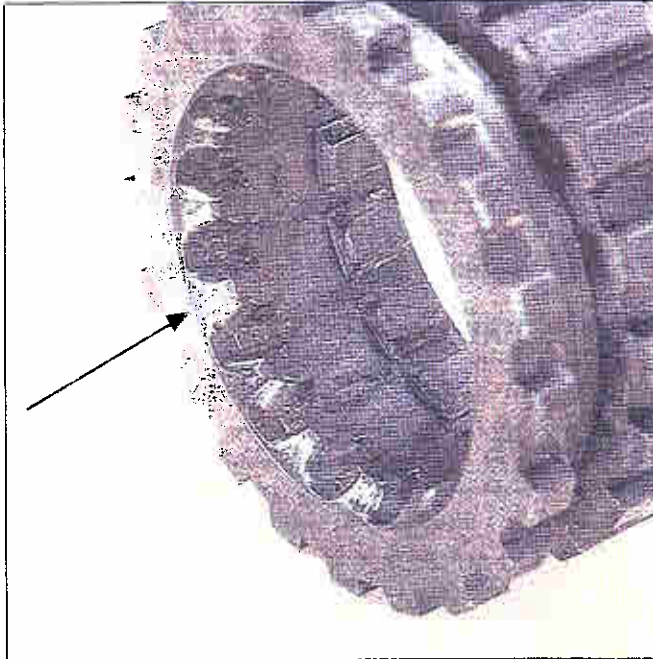

Figure 9—Worn clutching teeth.

To prevent clash shifting:

- Make sure the driver is familiar with both the shift pattern and the required RPM changes between shifts.
- Establish correct clutch adjustment to prevent inadequate clutch release or dragging.
- In air shifted transmissions, make sure the pressure regulator is at the proper setting—usually 55 - 60 psi.

⚠ See SHIFTING CAUTION (pg. 6).

Bearings

The service life of most transmissions is determined by the life of its bearings. Many premature bearing failures are caused by vibration or contamination. If bearings are stored, it's very important to coat them with a rust inhibitor and keep them tightly wrapped to prevent contamination.

Other reasons for bearing failures include:

- Lack of lubricant or contaminated lubricant
- Improper assembly
- Overloading
- Misalignment

Offset spalling (see Figure 10), is caused by misalignment of the transmission in relation to other drivetrain components.



Figure 10—Offset spalling is caused by misalignment.

Offset spalling is similar in appearance to destructive pitting, but craters are larger in diameter and shallower in depth. Spalling occurs over a short period of time when a bearing is subjected to an extreme overload condition.



Figure 11—Seized bearing.

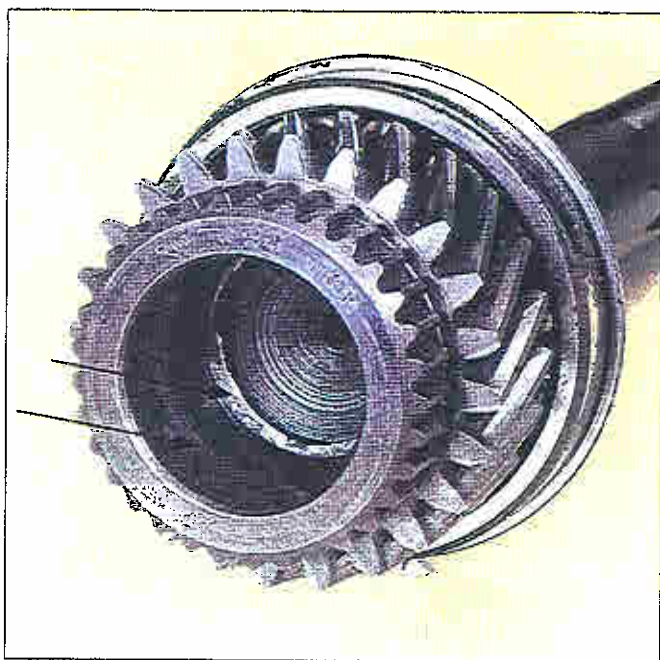

Figure 12—Lack of lubrication to the pocket bearing resulted in a bearing seizing to this input shaft (note the ring of metal).

If a bearing isn't properly lubricated, bearings may seize (see Figures 11 and 12). Discoloration, especially a blue tint, is a sign of heat. Heat is generally caused by improper lubrication. This can mean the wrong type of lubricant, not enough or too much lubricant, using lubricant past its useful life, or using contaminated lubricant.

⚠ See LUBRICATION CAUTION (pg. 3).

Forks

Clash shifting and over-shifting (going beyond the shift rail detent position) are two obvious causes of fork pad and fork shoe wear (see Figures 13 and 14). A third cause is using the shift lever as a hand rest. Prevent these problems through driver awareness and training.

⚠ See SHIFTING CAUTION (pg. 6).

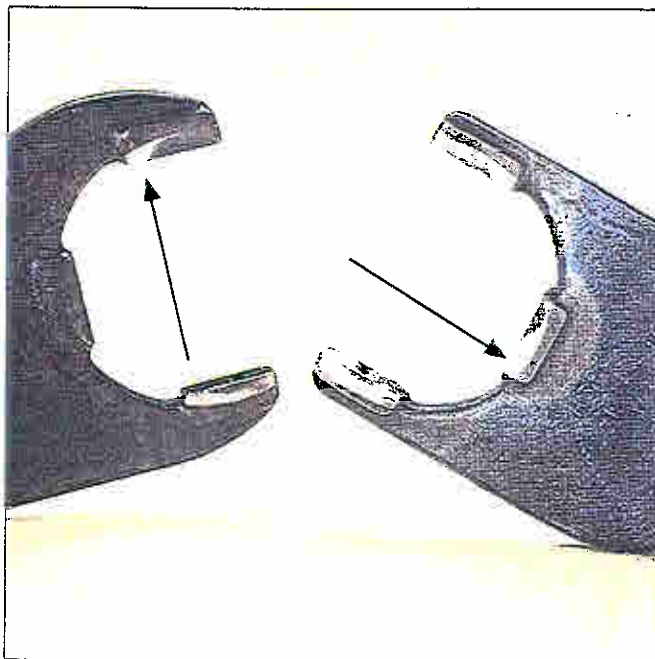

Figure 13—Fork pad wear.

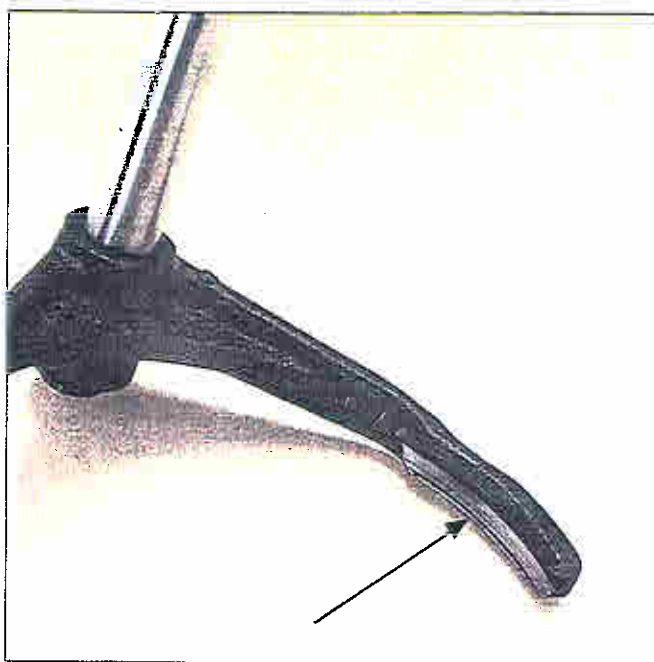

Figure 14—Fork shoe wear.

A fourth, less obvious cause of fork pad wear is a loose output nut. A loose output nut will allow the mainshaft to move back and forth. This motion not only can damage the shift forks, but can crack or break thrust washers. To prevent this, always tighten the output nut to the torque specifications listed in your Spicer transmission service manual.

Synchronizers

Some of the leading causes of synchronizer failure include improper shifting techniques, vibration, and lubrication problems.

Starting the vehicle in the proper gear:

An empty truck can be started satisfactorily in a higher transmission gear ratio than when partially or fully loaded. If auxiliary transmissions or two-speed axles are used, they must be in the lower ratios for satisfactory starts. Drivers should be shown what ratios can be used for safe starts when the truck is empty or loaded. Don't let drivers find out for themselves; they can damage synchronizers. If the truck is diesel powered, a good rule of thumb for the driver to follow is: *empty or loaded, select the gear combination that lets you take up the slack and start moving with an idling engine or, if necessary, just enough throttle to prevent stalling the engine.* After the clutch is fully engaged, the engine should be accelerated to near governed speed for the upshift into the next higher gear.

When shifting a synchronized transmission, it is important to move the shift lever in one motion until the shift is completed. "Stabbing" the shift lever will result in gear clashing. Another result will be worn clutching teeth (see Figure 15) and metal chips embedded into the brass synchronizer ring (see Figure 16). When the synchronizer ring makes contact with the desired gear, the blockers automatically prevent the shift collar from completing the shift until the gear and mainshaft speeds are matched. At that time, the blocker neutralizes automatically, and the clash-free shift is the result. It must be noted that a steady pressure on the shift lever helps the synchronizer do its job quickly.

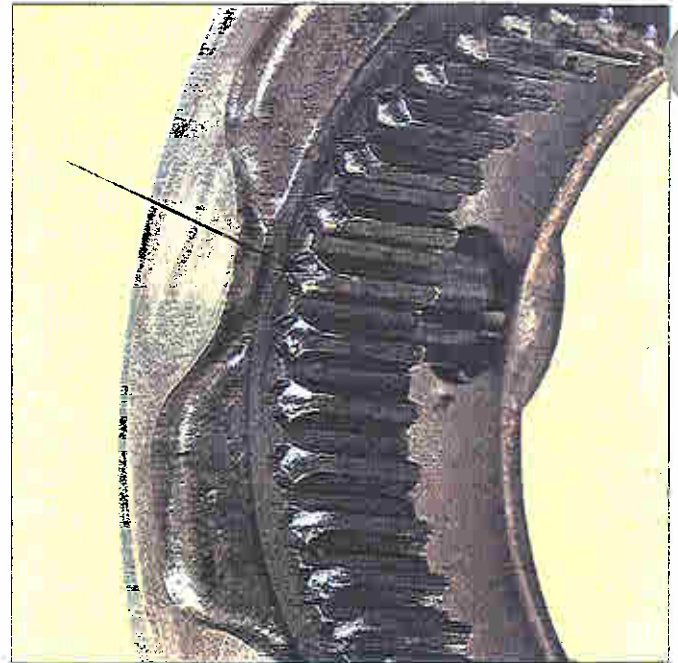

Figure 15—Improper shifting techniques cause worn synchronizer clutching teeth.

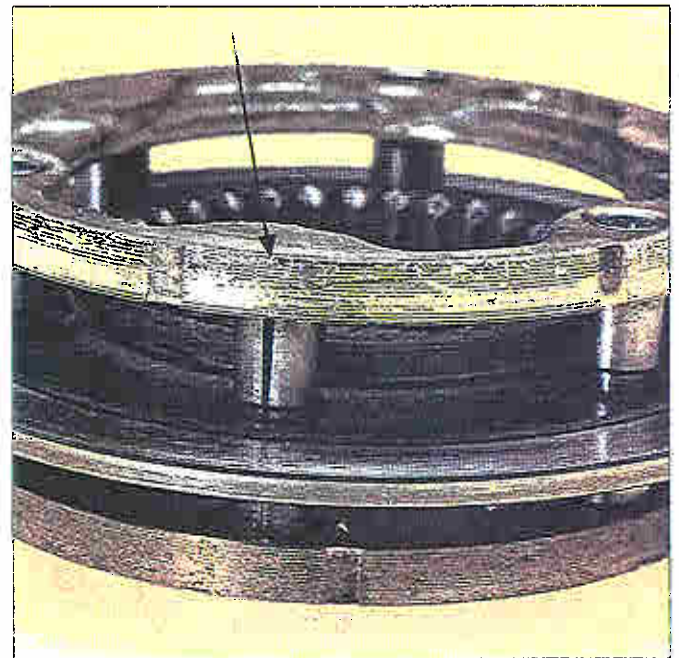

Figure 16—Metal chips are caused by clash shifting or lack of lubrication.

Another aspect of improper shifting involves vehicles with power take-offs (PTOs). **Never** shift from one gear into another while the PTO is engaged. The PTO will act like a brake, slowing countershaft and input shaft rotation. The synchronizer will try to match the mainshaft speed while the PTO will work against it.

 See **SHIFTING CAUTION** (pg. 6).

Vibration is another big cause of synchronizer failures. Broken or sheared synchronizer pins are a very common sign of vibration (see Figure 17). The brass synchronizer ring may also be pushed off the pins due to vibration (see Figure 18).

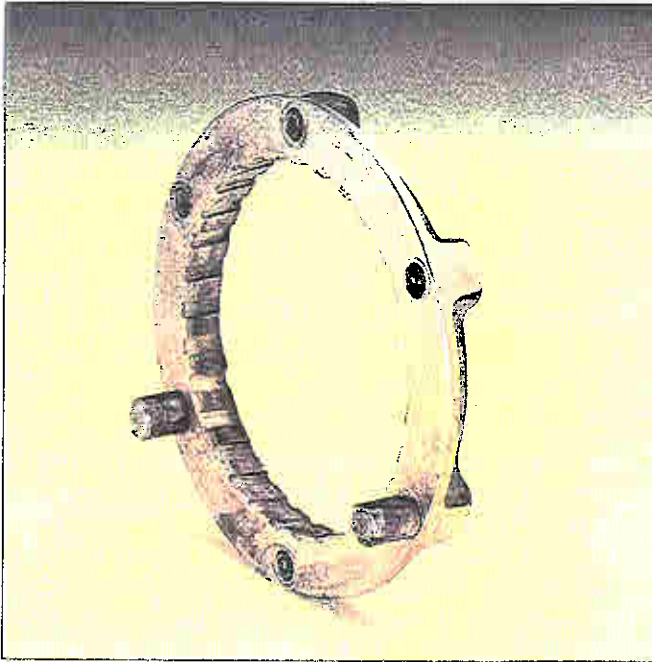

Figure 17—Sheared synchronizer pins are a sign of vibration.



Figure 18—Vibration can cause the brass ring to separate from the rest of the synchronizer.

Refer to the *Vibration* section of this publication (page 2) for information on causes of vibration.

It is also important to maintain proper lubrication levels. See the *Heat and Lubrication* section of this publication (page 2) for more information.

⚠ See VIBRATION WARNING and LUBRICATION CAUTION (pgs. 2 and 3).

Shafts

When gears, clutch collars, clutch gear, or synchronizers show signs of clash shifting, carefully examine shaft gearlocks. If they are worn (see Figure 19), the shaft must be replaced to protect against gear jumping.

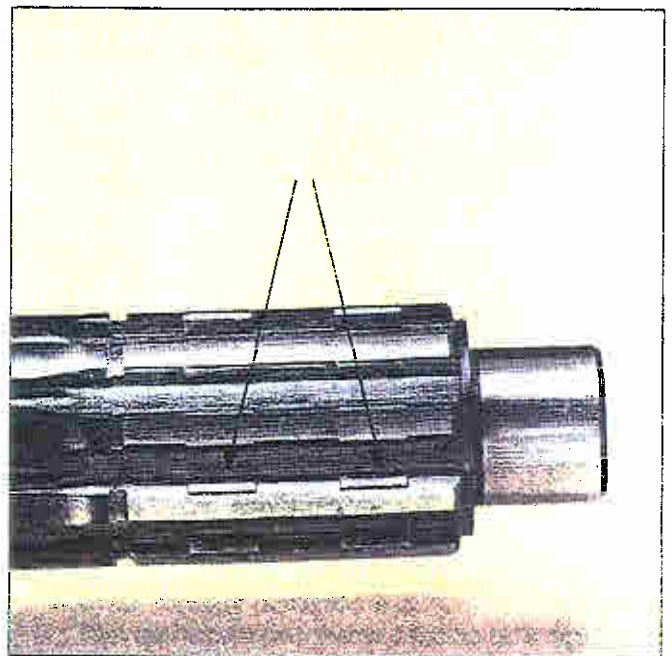

Figure 19—Worn shaft gearlocks can lead to gear jumping.

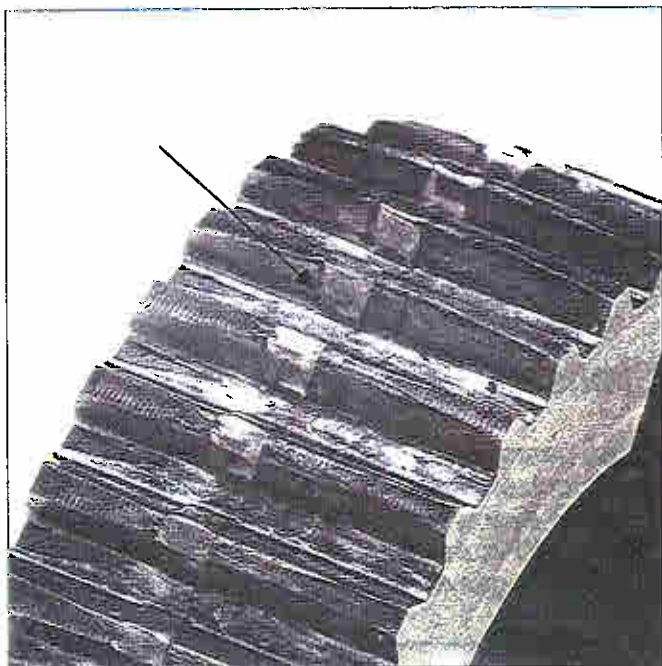

Figure 20—Worn gear locks on the clutch gear can lead to gear jumping.

Also examine gear locks on the clutch gear. Worn gear locks on mainshaft clutch gears contribute to gear jumping (see Figure 20). If gear locks are worn, replace them. Also check for proper clutch adjustment and verify that transmission lubrication is correct.

Also check the output end of the shaft for signs of end yoke vibration. This is indicated by a shiny area on the output yoke shaft splines (see Figure 21). This problem can be avoided by tightening the yoke nut to the specifications listed in the Spicer service manual.

Fretting corrosion is a common type of surface damage that occurs when two materials rub while vibrating very slightly. Such corrosion is common at surfaces of splines and other close-fitting parts that are subject to minute relative movement.

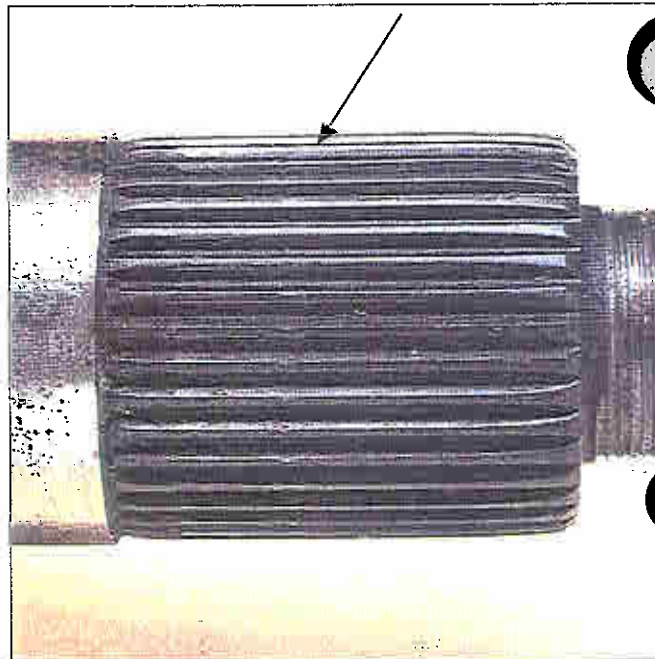

Figure 21—Shiny areas on the output yoke splines indicated end yoke vibration.

Gear seizures and discoloration of the shaft—especially a blue hue—indicate heat problems (see Figures 22 and 23). Heat problems can be traced to inadequate lubrication, using the wrong type of lubricant, or not changing the lubricant frequently enough.

⚠ See LUBRICATION CAUTION (pg. 3).

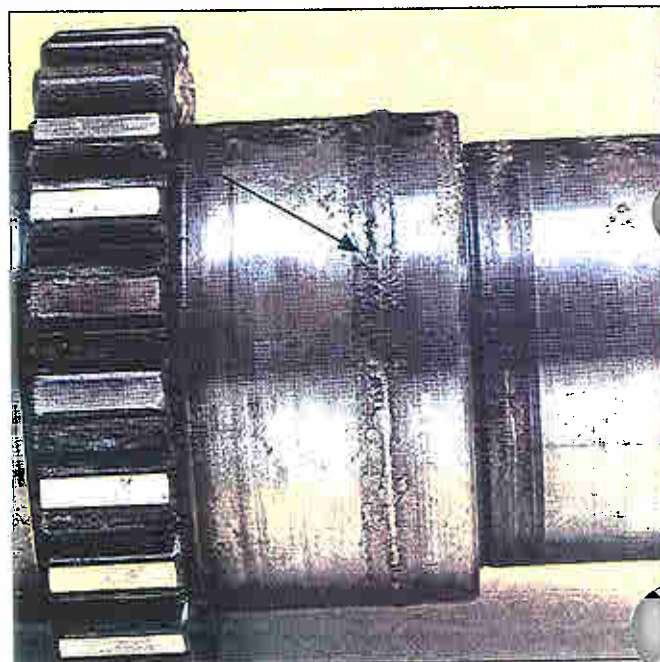

Figure 22—A gear seized on this shaft, leaving metal deposits.

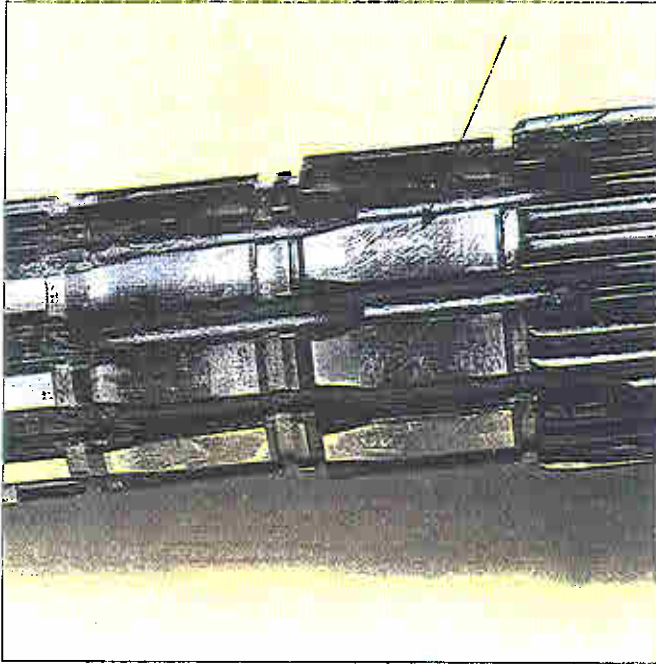

Figure 23—Discoloration is a sign of heat, which is related to lubrication problems.

Improper driveline angles or offset, out-of-phase universal joints will cause torsional vibrations severe enough to break down oil film. For more information on proper lubrication, see the *Heat and Lubrication* section of this publication (page 2), and review the specifications in your service manual.

A third big cause of shaft failures is shockloading (see Figure 5).

⚠ See VIBRATION WARNING and LUBRICATION CAUTION (pgs. 2 and 3).

Transmission seals are the most common cause of problems in vehicle transmissions. If the problem is not repaired properly, major transmission failure can result. Spicer transmissions have seals with an improved design that use new sealing materials.

Causes of Seal Failure

■ Contamination

- Dirt
- Oil
- Grease
- Water

■ Faulty Repairs

- Damaged output yoke
- Incorrect diameter yoke sleeve
- Seal lip damage during installation
- Output yoke seal surface not machined properly
- Attempted manual repair of yoke with emery cloth
- Output bearing wear and / or failure causing excessive runout or endplay

■ Improper Installation

- Use of improper tools
- Improper installation of the oil seal in the bearing cap (seal cocked in bearing cap bore)
- Installation of damaged yoke or input shaft with burrs or nicks

■ Storage and Handling Damage

- Improper storage of oil seals
- Improper protection on output yoke or input shaft sealing surfaces
- Improper method used to prevent sealing surface from rusting

■ Excessive Heat

- Breakdown of lubrication
- Use of improper lubrication
- Use of lubricant not compatible with seal material

Front Bearing Retainer & Seal

! When installing the front bearing retainer and seal in the transmission, use the red plastic sleeve to prevent serious damage to the oil seal. Failure to use the seal sleeve will void the seal warranty.

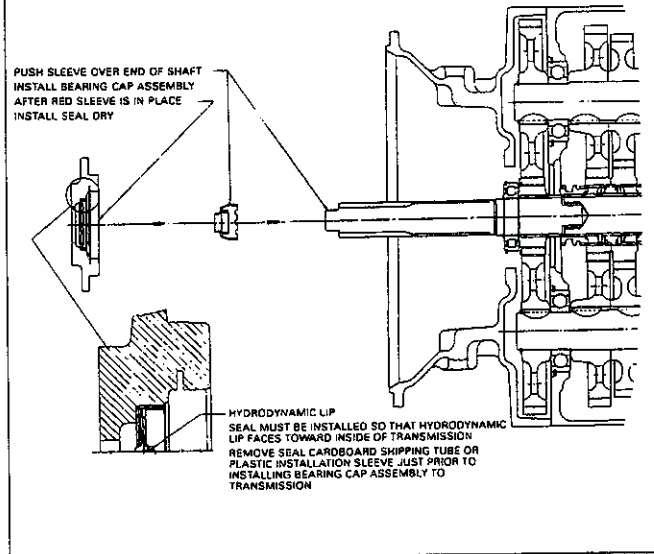

Product Warranty

A transmission product warranty covers repairs when the product proves defective in normal use.

Normal Wear

All components will wear—to a certain degree—under normal operating conditions. New units have an initial break-in period in which components wear until mating with one another, resulting in greater contact surfaces. The most important factor in keeping wear to a minimum is adhering to proper maintenance schedules and including an inspection of transmission components and lubrication. If components with excessive wear are found, check and replace them as needed. Replacing worn parts is less costly than replacing an entire unit later.

NOTE: Always use the correct maintenance manual and genuine Spicer transmission parts to ensure a proper repair.

Non-Warrantable Conditions

The following photos show examples of non-warrantable conditions. These conditions are due to misuse, negligence, improper maintenance or improper operation.

Lubrication Failure



Pitting, scoring and galling can occur when the gear material endurance limit is exceeded. Lubrication problems can also contribute to these conditions.

Shockload

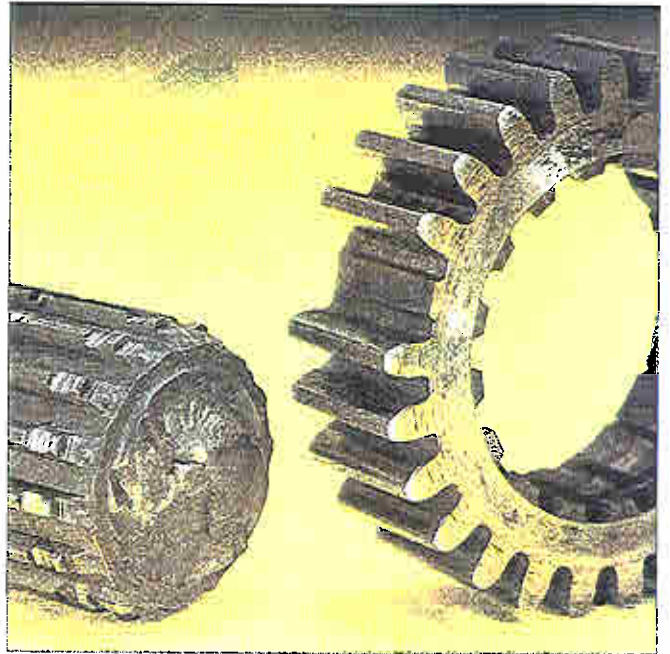

A broken shaft and missing gear teeth indicate shockload.

Clash Shifting



Worn clutching teeth indicate a clash shifting condition.

Torsional Vibration



Vibration can cause the brass ring to separate from the rest of the synchronizer. Sheared synchronizer pins are also a sign of vibration.

Over-Shifting

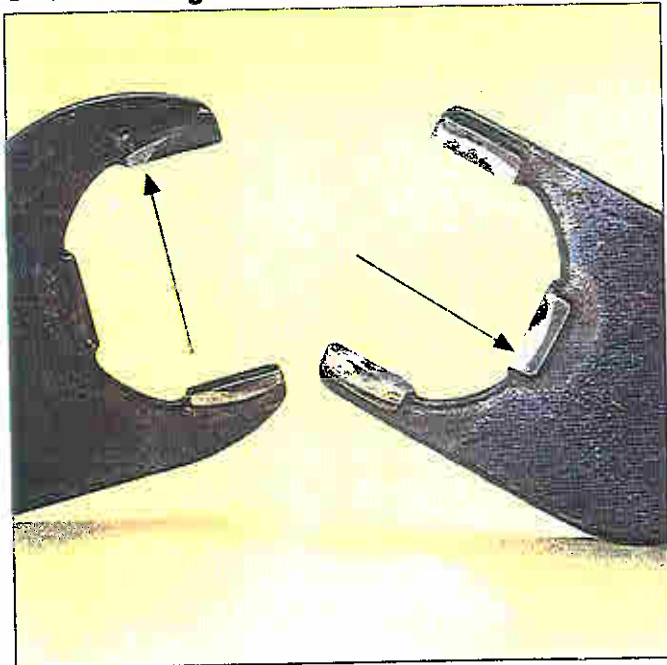

Fork pad wear is caused by over-shifting and clash shifting.

Torsional Vibration

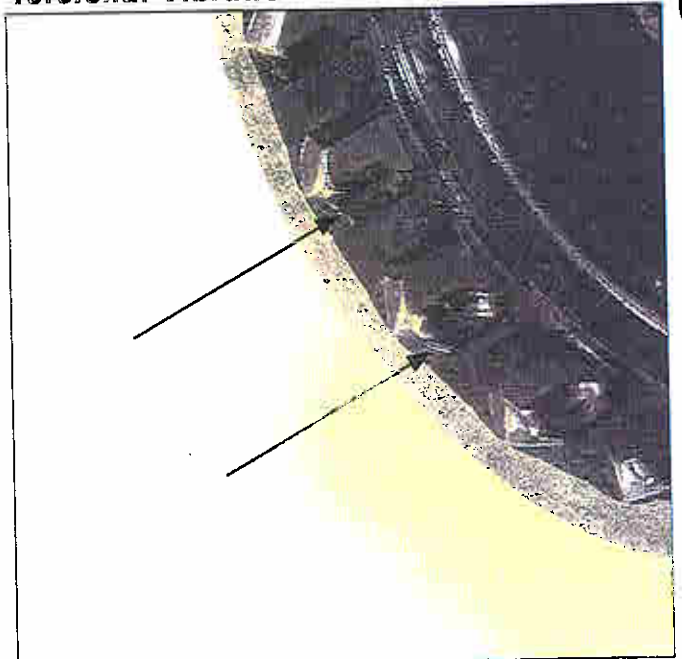

Torsional vibration caused these worn teeth.

Addendum - portion of a gear tooth between the pitch line and the tip of the tooth

Beach Marks - visible lines on a fatigue fracture that show the location of the tip of the fatigue crack

Contaminate - to make impure by foreign material

Clutch Collar - device used to engage from one gear to another

Dedendum - portion of a gear tooth between the pitch line and the root of the tooth

Fatigue Failure - minute cracks that grow under the action of fluctuating stresses

Fracture - break or separation of a part into two or more pieces

Fretting Corrosion - surface damage that occurs when two materials rub while vibrating slowly

Gear - mechanical part to transmit motion

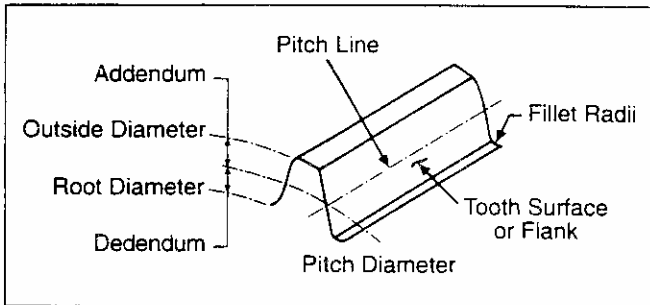

Gear Jumping - shift lever movement out of a selected position

Gear Locks - device to keep a gear engaged

Hard Shifting - use of excessive force to move the shift lever

Offset Spalling - caused by a bearing being subjected to extreme overload conditions in a short period of time

Oil Seal - device used to confine oil to a certain area

Pitch Line - location of a gear tooth midway up the tooth

Pitting - resulting marks when the endurance limit of the material is exceeded

Proper Lubrication - describes a transmission that has the proper oil level and recommended oil type

Root Diameter - innermost part of a stress concentration, such as the bottom of a groove

Scoring - resulting marks caused by excessive heat generation in the gear mesh

Seized - condition caused by a lack of lubricant and the presence of high heat

Shockload - violent impact on a gear tooth that usually causes the tooth to break

Torsional Vibration - twisting action that may be either reversed (back and forth) or unidirectional (one way)



14700 Helm Court
Plymouth, MI 48170
(800) 401-9866 or (734) 456-3770
Fax: (734) 456-3739
www.ttcautomotive.com

