

SPICER LITE 10-SPEED Overdrive Transmissions

SPICER®

**SPICER LITE™
10-SPEED
OVERDRIVE
TRANSMISSIONS**

WITH OPTILUBE™

The Spicer Lite and Spicer Lite-2™ Overdrive 10-Speeds are the best choice when weight-sensitive or bulk hauling applications call for an overdrive transmission. Heat-treated aluminum alloy cases allow increased payload capacity and more profit. Key advantages are:

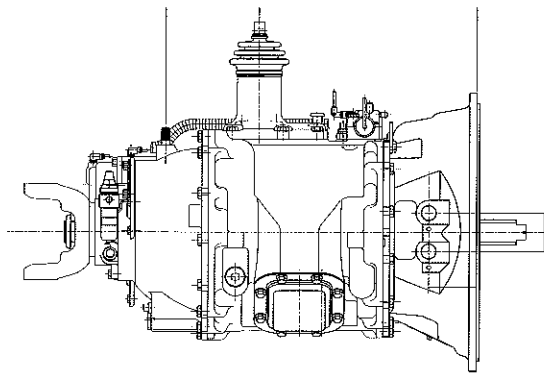

- ◆ Up to 72-pound weight savings with Spicer Lite models
- ◆ Up to 142-pound weight savings with Spicer Lite-2 models
- ◆ Optilube system eliminates need for oil cooler, and uses 9 pints less lube for additional weight savings
- ◆ Enhanced operating efficiency

MODEL SPECIFICATIONS

SPICER LITE			
MODEL	TORQUE CAPACITY	WEIGHT*	GVW/GCW**
LPSO100-10S	1,000 lb. ft. (138 kgm)	580 lbs.	80,000 lbs.
LPSO125-10S	1,250 lb. ft. (173 kgm)	580 lbs.	120,000 lbs.
LPSO140-10S	1,400 lb. ft. (193 kgm)	580 lbs.	140,000 lbs.
LPSO150-10S	1,500 lb. ft. (207 kgm)	580 lbs.	140,000 lbs.

SPICER LITE-2			
MODEL	TORQUE CAPACITY	WEIGHT*	GVW/GCW**
LLPSO100-10S	1,000 lb. ft. (138 kgm)	517 lbs.	80,000 lbs.
LLPSO125-10S	1,250 lb. ft. (173 kgm)	517 lbs.	120,000 lbs.
LLPSO140-10S	1,400 lb. ft. (193 kgm)	517 lbs.	140,000 lbs.
LLPSO150-10S	1,500 lb. ft. (207 kgm)	517 lbs.	140,000 lbs.

PERFORMANCE CHART

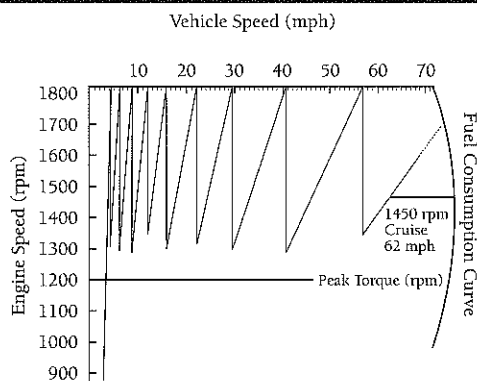

GENERAL INFORMATION

Ratio Coverage	16.7:1
Length	31.00" (787 mm)
Input Shaft	2" 10-Spline
Output Shaft	2-1/2" 10-Spline
Clutch Housing	Aluminum SAE #1
Clutch	14" or 15.5"
Lube System	Optilube
Lube Capacity	18 Pints (8.5 Liters)
Lube Type	SAE 50 H.D. - engine oil

* Includes clutch housing.

** All other applications require Spicer Engineering approval.

The Spicer Lite and Spicer Lite-2 transmissions feature even steps for smooth shifting from start to cruise.

TTC

SPICER LITE 10-SPEED Overdrive Transmissions

TOP GEARED MPH*

AXLE RATIO	ENGINE RPM							
	1400	1500	1600	1700	1800	1900	2000	2100
3.21	67	72						
3.42	63	68	72					
3.55	61	65	70					
3.73	58	62	66	71				
3.90	56	60	63	67	71			
4.10		57	60	64	68	72		
4.33			57	61	64	68	71	
4.44			56	59	63	66	70	78
4.56				58	61	64	68	71
4.63				57	60	63	67	70
4.88					57	60	63	67
5.29						56	59	61
5.86								55

* With tires @ 517 revolutions per mile.

TOTAL REDUCTION

SPICER OVERDRIVE 10-SPEEDS WITH 12.54 FIRST GEAR

AXLE RATIO	TOTAL REDUCTION
3.21	40:1
3.42	43:1
3.55	45:1
3.73	47:1
3.90	49:1
4.10	51:1
4.33	54:1
4.44	56:1
4.56	57:1
4.63	58:1
4.88	61:1
5.29	66:1
5.86	73:1

GEAR RATIOS ALL MODELS

GEAR	RATIO	STEP
1st	12.54	
2nd	9.54	36%
3rd	6.58	38%
4th	4.80	39%
5th	3.60	33%
6th	2.61	38%
7th	1.92	36%
8th	1.39	38%
9th	1.00	39%
10th	.75	33%
Reverse	14.02	
Overall Ratio Coverage	16.74	

SPICER LITE SHIFT PATTERN

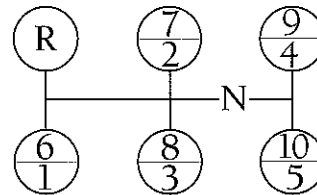

POWER TAKE-OFF APPLICATIONS

TRANSMISSION	P.T.O. GEAR DATA	POSITIONS
All Models	85% Engine Speed, 45 Tooth, 6 Pitch	6 Bolt Right, 8 Bolt Left

SPICER END FITTING REFERENCE

END YOKE	QUICK DISCONNECT™
1710	6-4-6611-1
1760 & 1760HD	6.3-4-651-1
1810	6.5-4-3451-1

FLANGE	NUMBER OF BOLT HOLES
1710	8
1810	12



14700 Helm Court
Plymouth, MI 48170
(800) 401-9866 or (734) 456-3770
Fax: (734) 456-3739
www.ttcautomotive.com

